

WIPER SEALS

BECA 482



DESCRIPTION

The BECA 482 profile is a double acting composite wiper seal composed of a filled PTFE friction ring and a pre-tightened rubber O'Ring.

ADVANTAGES

Low friction coefficient;
no stick-slip effect

Wide temperature range and excellent chemical resistance, depending on the materials selected

Excellent abrasion and wear resistance

Very good wiping effect against external pollutions

APPLICATIONS

Shock absorbers
Standard cylinders

MATERIALS

Friction ring

Bronze-filled PTFE
Carbon-filled PTFE
Virgin PTFE

O'Ring

NBR 70 Shore A

Other grades of materials are available. Please refer to the materials table on the next page.

TECHNICAL DATA

Temperature	-30°C / +200°C
Speed	5 m/s
Media	Lubricated air Oil-free air Non-aggressive gases

The figures above indicate the maximum values and may not be cumulated. They may be developed, depending on the materials used.

SURFACE ROUGHNESS

Roughness	Dynamic surface area	Static surface area	Groove flanks
Ra	0.05 - 0.2 µm	≤1.6 µm	≤3.2 µm
Rz	0.4 - 1.6 µm	≤6.3 µm	≤10.0 µm
Rmax	0.63 - 2.5 µm	≤10.0 µm	≤16.0 µm

RADIUS

Radial section S	Radius R1	Radius R2
2.40	0.20	0.40
3.40	0.20	0.80
4.40	0.20	1.00
6.10	0.20	1.50
8.00	0.20	1.50
10.00	0.20	2.00

CHAMFER

The chamfer length as well as the chamfer angle are determined by the rod seal.

TABLE MATERIALS

Friction ring					O'Ring			Mating surface material	
Standard code	ISO code	Material	Colour	Characteristics	Code	Type of material	Service temperature		
DP	P	Virgin PTFE	White	Resistance to chemical products Impermeability Dielectric Non-stick Low friction coefficient Food industry	K6	NBR 70 Shore A	-30°C/+100°C	Steel Stainless steel Chrome steel Aluminium Bronze Cast iron Treated surface	
					G6	FKM 70 Shore A	-20°C/+200°C		
					C6	EPDM 70 Shore A	-45°C/+150°C		
					F6	VMQ 70 Shore A	-60°C/+200°C		
DC	C	PTFE + 25% Carbon	Grey	Improvements • Wear properties • Compression set Good resistance to chemical products Thermal and electrical conductivity Anti-static High-performing in compression-based dynamic applications	K6	NBR 70 Shore A	-30°C/+100°C		
					G6	FKM 70 Shore A	-20°C/+200°C		
					C6	EPDM 70 Shore A	-45°C/+150°C		
CG	C	PTFE + 23% Carbon + 2% Graphite	Black	Thermal and electrical conductivity Anti-static High-performing in compression-based dynamic applications	K6	NBR 70 Shore A	-30°C/+100°C		
					G6	FKM 70 Shore A	-20°C/+200°C		
					C6	EPDM 70 Shore A	-45°C/+150°C		
DV	V	PTFE + 25 % Glass	Blue	Improvements • Wear properties • Mechanical strength Slightly more abrasive, however, this is corrected by adding MOS2 Maintains its chemical and dielectric properties Well-suited to applications with rotational and simultaneous alternating movements	K6	NBR 70 Shore A	-30°C/+100°C		Steel Chrome steel Cast iron
					G6	FKM 70 Shore A	-20°C/+200°C		
VM	M	PTFE + 15 % Glass + 5% MOS2	Grey	Well-suited to applications with rotational and simultaneous alternating movements	K6	NBR 70 Shore A	-30°C/+100°C		
					G6	FKM 70 Shore A	-20°C/+200°C		
DX	X	PTFE GL Blue + Glass + Metal oxides	Turquoise blue	Resistance to compression Resistance to wear Excellent chemical stability Good thermal conductivity	K6	NBR 70 Shore A	-30°C/+100°C		
					G6	FKM 70 Shore A	-20°C/+200°C		
DG	G	PTFE + 15% Graphite	Black	Improvements • Wear properties Reduced wear on metal parts Self-lubricating Thermal and electrical conductivity Low permeability Good friction coefficient Anti-static High performing in dynamic self-lubricating applications	K6	NBR 70 Shore A	-30°C/+100°C	Steel Stainless steel Chrome steel Aluminium Bronze Cast iron Treated surface	
					G6	FKM 70 Shore A	-20°C/+200°C		
					C6	EPDM 70 Shore A	-45°C/+150°C		
K1	K	PTFE + 10% Ekonol	Light brown	Improvements • Better abrasion resistance • Better dimensional stability at high temperatures Use up to +300°C Good friction coefficient and low permeability	K6	NBR 70 Shore A	-30°C/+100°C		
					G6	FKM 70 Shore A	-20°C/+200°C		
					C6	EPDM 70 Shore A	-45°C/+150°C		
K2	K	PTFE + 20% Ekonol	Light brown	Use up to +300°C Good friction coefficient and low permeability	K6	NBR 70 Shore A	-30°C/+100°C		
					G6	FKM 70 Shore A	-20°C/+200°C		
					C6	EPDM 70 Shore A	-45°C/+150°C		
DB	B	PTFE + 60% Bronze	Dark brown	Improvements • Wear properties • Warping resistance and creep strength • Compression resistance Self-lubricating Electrical and thermal conductivity Does not alter the metal parts Reduced hold with certain chemical products Used for high-compression dynamic seals and has a low level of wear	K6	NBR 70 Shore A	-30°C/+100°C	Steel Chrome steel Cast iron	
					G6	FKM 70 Shore A	-20°C/+200°C		
B4	B	PTFE + 40% Bronze	Dark brown	Used for high-compression dynamic seals and has a low level of wear	K6	NBR 70 Shore A	-30°C/+100°C		
					G6	FKM 70 Shore A	-20°C/+200°C		

Other grades of materials are available depending on your specificities.

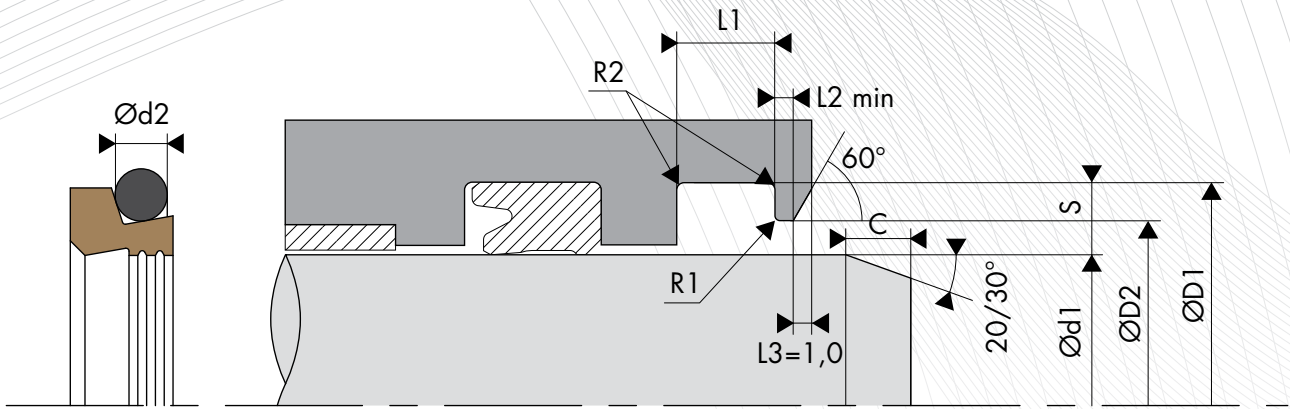

○ INSTALLATION DIMENSIONS

Rod diameter Ød1 f8/h9		Groove diameter	Bore diameter	Groove width	Step width	O'Ring cross-section
Standard range	Extended range	ØD1 H9	ØD2 H11	L1 0/+0.20	L2 min	Ød2
4.0 - 11.9	4.0 - 130.0	d1 + 4.80	d1 + 1.50	3.70	2.00	1.78
12.0 - 64.9	10.0 - 245.0	d1 + 6.80	d1 + 1.50	5.00	2.00	2.62
65.0 - 250.9	25.0 - 400.0	d1 + 8.80	d1 + 1.50	6.00	3.00	3.53
251.0 - 420.9	40.0 - 655.0	d1 + 12.20	d1 + 2.00	8.40	4.00	5.33
421.0 - 650.9	110.0 - 655.0	d1 + 16.00	d1 + 2.00	11.00	4.00	6.99
651.0 - 999.9	140.0 - 999.9	d1 + 20.00	d1 + 2.50	14.00	5.00	8.40

○ EXAMPLE OF CODIFICATION

STANDARD CODIFICATION

Materials _____ : Friction ring, PTFE + 60% Bronze - Code DB
 _____ : NBR 70 Shore A O'Ring - Code K6
 Rod diameter _____ : Ød1 + 50.00 mm
 Groove diameter _____ : ØD1 = 56.80 mm
 Part number _____ : 482.050DBK6

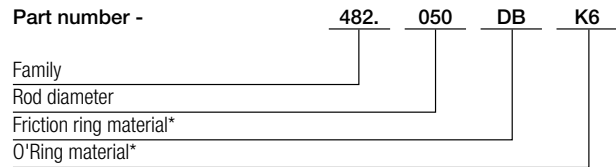

* The codes that define the materials are set out in the materials table on the previous page.

 DIMENSIONS

Part number	Rod diameter Ød1 f8/h9	Groove diameter ØD1 H9	Bore diameter ØD2 H11	Groove width L1 0/+0.20	Step width L2 min
482.004	4.00	8.80	5.50	3.70	2.00
482.005	5.00	9.80	6.50	3.70	2.00
482.006	6.00	10.80	7.50	3.70	2.00
482.008	8.00	12.80	9.50	3.70	2.00
482.009	9.00	13.80	10.50	3.70	2.00
482.010	10.00	14.80	11.50	3.70	2.00
482.012	12.00	18.80	13.50	5.00	2.00
482.014	14.00	20.80	15.50	5.00	2.00
482.015	15.00	21.80	16.50	5.00	2.00
482.016	16.00	22.80	17.50	5.00	2.00
482.018	18.00	24.80	19.50	5.00	2.00
482.020	20.00	26.80	21.50	5.00	2.00
482.022	22.00	28.80	23.50	5.00	2.00
482.025	25.00	31.80	26.50	5.00	2.00
482.028	28.00	34.80	29.50	5.00	2.00
482.030	30.00	36.80	31.50	5.00	2.00
482.032	32.00	38.80	33.50	5.00	2.00
482.035	35.00	41.80	36.50	5.00	2.00
482.036	36.00	42.80	37.50	5.00	2.00
482.037	37.00	43.80	38.50	5.00	2.00
482.038	38.00	44.80	39.50	5.00	2.00
482.040	40.00	46.80	41.50	5.00	2.00
482.042	42.00	48.80	43.50	5.00	2.00
482.045	45.00	51.80	46.50	5.00	2.00
482.048	48.00	54.80	49.50	5.00	2.00
482.049	49.00	55.80	50.50	5.00	2.00
482.050	50.00	56.80	51.50	5.00	2.00
482.052	52.00	58.80	53.50	5.00	2.00
482.054	54.00	60.80	55.50	5.00	2.00
482.055	55.00	61.80	56.50	5.00	2.00
482.056	56.00	62.80	57.50	5.00	2.00
482.058	58.00	64.80	59.50	5.00	2.00
482.060	60.00	66.80	61.50	5.00	2.00
482.062	62.00	68.80	63.50	5.00	2.00
482.063	63.00	69.80	64.50	5.00	2.00
482.065	65.00	73.80	66.50	6.00	3.00
482.068	68.00	76.80	69.50	6.00	3.00
482.070	70.00	78.80	71.50	6.00	3.00
482.075	75.00	83.80	76.50	6.00	3.00
482.080	80.00	88.80	81.50	6.00	3.00
482.085	85.00	93.80	86.50	6.00	3.00
482.090	90.00	98.80	91.50	6.00	3.00
482.095	95.00	103.80	96.50	6.00	3.00
482.100	100.00	108.80	101.50	6.00	3.00
482.105	105.00	113.80	106.50	6.00	3.00
482.110	110.00	118.80	111.50	6.00	3.00
482.115	115.00	123.80	116.50	6.00	3.00
482.120	120.00	128.80	121.50	6.00	3.00
482.125	125.00	133.80	126.50	6.00	3.00
482.130	130.00	138.80	131.50	6.00	3.00
482.135	135.00	143.80	136.50	6.00	3.00
482.140	140.00	148.80	141.50	6.00	3.00
482.145	145.00	153.80	146.50	6.00	3.00
482.150	150.00	158.80	151.50	6.00	3.00
482.155	155.00	163.80	156.50	6.00	3.00
482.160	160.00	168.80	161.50	6.00	3.00
482.165	165.00	173.80	166.50	6.00	3.00
482.170	170.00	178.80	171.50	6.00	3.00
482.175	175.00	183.80	176.50	6.00	3.00
482.180	180.00	188.80	181.50	6.00	3.00
482.185	185.00	193.80	186.50	6.00	3.00
482.190	190.00	198.80	191.50	6.00	3.00
482.195	195.00	203.80	196.50	6.00	3.00

Part number	Rod diameter Ød1 f8/h9	Groove diameter ØD1 H9	Bore diameter ØD2 H11	Groove width L1 0/+0.20	Step width L2 min
482.200	200.00	208.80	201.50	6.00	3.00
482.205	205.00	213.80	206.50	6.00	3.00
482.210	210.00	218.80	211.50	6.00	3.00
482.215	215.00	223.80	216.50	6.00	3.00
482.220	220.00	228.80	221.50	6.00	3.00
482.230	230.00	238.80	231.50	6.00	3.00
482.240	240.00	248.80	241.50	6.00	3.00
482.250	250.00	258.80	251.50	6.00	3.00
482.260	260.00	272.20	262.00	8.40	4.00
482.270	270.00	282.20	272.00	8.40	4.00
482.280	280.00	292.20	282.00	8.40	4.00
482.290	290.00	302.20	292.00	8.40	4.00
482.300	300.00	312.20	302.00	8.40	4.00
482.310	310.00	322.20	312.00	8.40	4.00
482.320	320.00	332.20	322.00	8.40	4.00
482.330	330.00	342.20	332.00	8.40	4.00
482.340	340.00	352.20	342.00	8.40	4.00
482.350	350.00	362.20	352.00	8.40	4.00
482.360	360.00	372.20	362.00	8.40	4.00
482.370	370.00	382.20	372.00	8.40	4.00
482.380	380.00	392.20	382.00	8.40	4.00
482.390	390.00	402.20	392.00	8.40	4.00
482.400	400.00	412.20	402.00	8.40	4.00
482.450	450.00	466.00	452.00	11.00	4.00
482.500	500.00	516.00	502.00	11.00	4.00