

INVERTED SHAFT SEALS

OSA2

DESCRIPTION

The OSA2 profile is an inverted shaft seal composed of a single internal metal cage with a metal reinforcement and a primary sealing lip with integrated spring.

ADVANTAGES

Excellent radial rigidity, particularly for large diameters

Very good stability when assembled, preventing the bounce-back effect

Sealing for low and high viscosity fluids

Modern primary sealing lip with low radial forces

Suitable for rotating hubs with a fixed shaft

APPLICATIONS

All types of rotative applications

Rotating hubs

Fixed shafts

MATERIALS

Rubber

ACM 70 - 75 Shore A

EPDM 70 - 75 Shore A

FKM 70 - 75 Shore A

HNBR 70 - 75 Shore A

NBR 70 - 75 Shore A

Metal cage

Steel - AISI 1010

Stainless steel - AISI 304

Stainless steel - AISI 316

Spring

Steel - AISI 1070 - 1090

Stainless steel - AISI 316

SEAL DESIGN

Tolerance for the inside diameter of the seal ($\varnothing d$)

| Shaft diameter $\varnothing d1$ (mm) | Apparent metal cage | Rubber coating | Coating with grooves |
|--------------------------------------|---------------------|----------------|----------------------|
| $\varnothing d1 \leq 50.0$ | -0.20 / -0.10 | -0.30 / -0.15 | -0.40 / -0.20 |
| $50.0 < \varnothing d1 \leq 80.0$ | -0.23 / -0.13 | -0.35 / -0.20 | -0.45 / -0.25 |
| $80.0 < \varnothing d1 \leq 120.0$ | -0.25 / -0.15 | -0.35 / -0.20 | -0.45 / -0.25 |
| $120.0 < \varnothing d1 \leq 180.0$ | -0.28 / -0.18 | -0.45 / -0.25 | -0.55 / -0.30 |
| $180.0 < \varnothing d1 \leq 300.0$ | -0.30 / -0.20 | -0.45 / -0.25 | -0.55 / -0.30 |
| $300.0 < \varnothing d1 \leq 500.0$ | -0.35 / -0.23 | -0.55 / -0.30 | -0.65 / -0.35 |

Roundness tolerance

| Shaft diameter $\varnothing d1$ (mm) | Apparent metal cage | Rubber coating |
|--------------------------------------|------------------------------|----------------|
| $\varnothing d1 \leq 50.0$ | 0.18 | 0.25 |
| $50.0 < \varnothing d1 \leq 80.0$ | 0.25 | 0.35 |
| $80.0 < \varnothing d1 \leq 120.0$ | 0.30 | 0.50 |
| $120.0 < \varnothing d1 \leq 180.0$ | 0.40 | 0.65 |
| $180.0 < \varnothing d1 \leq 300.0$ | 0.25% of the inside diameter | 0.80 |
| $300.0 < \varnothing d1 \leq 500.0$ | 0.25% of the inside diameter | 1.00 |

Tolerance for the outside diameter of the seal ($\varnothing D$)

Free and without constraint, the outside diameter of the sealing lip is always bigger than the diameter of the rotating hub. The pre-tightening or interference denotes the difference between these two values. Depending on the hub diameter, the diameter of the sealing lip is generally considered to be greater, between 0.8 and 3.5 mm.

Pumping leads

| Clockwise | Anti-clockwise | Bi-directional |
|-----------|----------------|----------------|
| | | |
| R | L | H0 |

Other types of pumping leads can be created according to your specifications. Please contact our experts.

TECHNICAL DATA

Speed

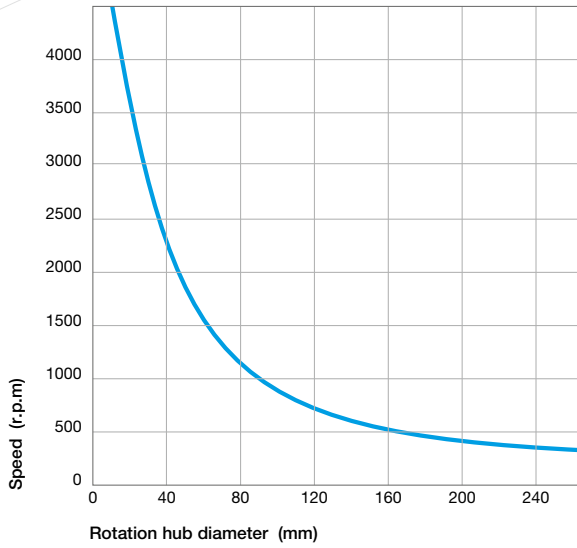

Linear speed calculation:

$$s \text{ (m/s)} = \frac{\text{rotating hub } \varnothing \text{ (mm)} \times \text{speed (rpm)} \times \pi}{60,000}$$

Pressure

The inverted shaft seals are generally used in unpressurised environments, or for pressures between 0.02 and 0.05 MPa (maximum).

Temperature / Media

| Media | | Maximum temperature depending on the materials | | | | | | |
|-----------------------|---|--|--------|--------|--------|--------|--------|--------|
| | | ACM | AEM | EPDM | FKM | HNBR | NBR | VMQ |
| Mineral oils | Oils for motors | +130°C | +130°C | - | +170°C | +130°C | +100°C | +150°C |
| | Oils for gearboxes | +120°C | +130°C | - | +150°C | +110°C | +80°C | +130°C |
| | Oils for hypoid gears | +120°C | +130°C | - | +150°C | +110°C | +80°C | - |
| | ATF oils | +120°C | +130°C | - | +170°C | +130°C | +100°C | - |
| | Hydraulic oils | +120°C | +130°C | - | +150°C | +130°C | +90°C | - |
| | Greases | - | +130°C | - | - | +100°C | +90°C | - |
| Fire-resistant fluids | HFA group - Emulsion with more than 80% water | - | - | - | - | +70°C | +70°C | +60°C |
| | HFB group - Opposite solution (water in oil) | - | - | - | - | +70°C | +70°C | +60°C |
| | HFC group - Polymer aqueous solution | - | - | +60°C | - | +70°C | +70°C | - |
| | HFD group - Water-free synthetic fluids | - | - | - | +150°C | - | - | - |
| Other fluids | EL + L heating oil | - | - | - | - | +100°C | +90°C | - |
| | Air | +150°C | +150°C | +150°C | +200°C | +130°C | +100°C | +200°C |
| | Water | - | - | +150°C | +100°C | +100°C | +90°C | - |
| | Water for washing | - | - | +130°C | +100°C | +100°C | +90°C | - |
| Temperature range | Min. | -25°C | -40°C | -45°C | -20°C | -30°C | -30°C | -60°C |
| | Max. | +150°C | +150°C | +150°C | +200°C | +150°C | +100°C | +200°C |

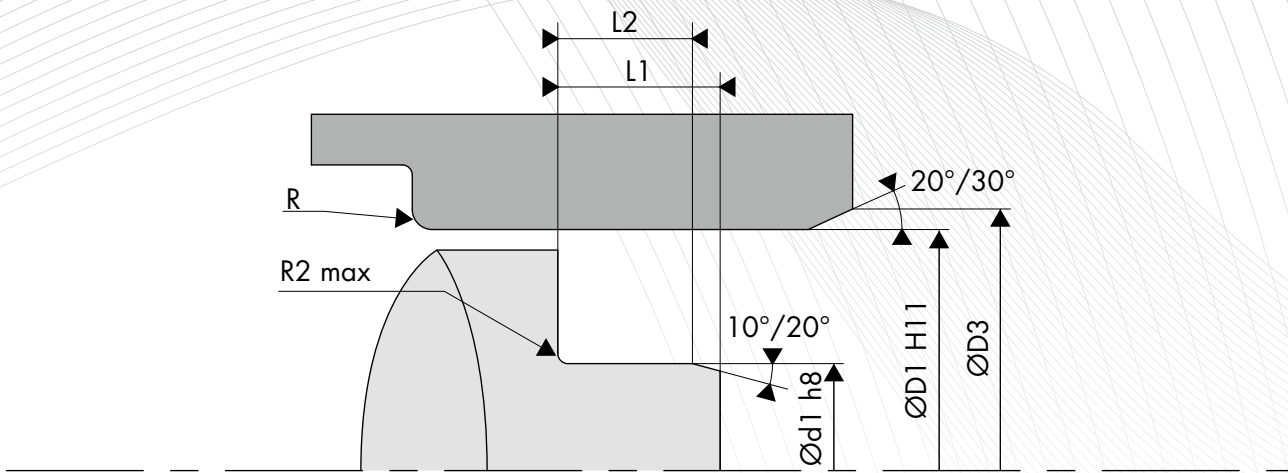

○ FIXED SHAFT DESIGN

Surface roughness

| | |
|------|----------------|
| Ra | 0.8 to 3.2 µm |
| Rz | 6.3 to 16.0 µm |
| Rmax | ≤16.0 µm |

Fixed shaft tolerance

| Shaft diameter Ød1 (mm) | Tolerance h8 (mm) |
|----------------------------|----------------------|
| 3.0 < Ød1 ≤ 6.0 | -0.018 / 0 |
| 6.0 < Ød1 ≤ 10.0 | -0.022 / 0 |
| 10.0 < Ød1 ≤ 18.0 | -0.027 / 0 |
| 18.0 < Ød1 ≤ 30.0 | -0.033 / 0 |
| 30.0 < Ød1 ≤ 50.0 | -0.039 / 0 |
| 50.0 < Ød1 ≤ 80.0 | -0.046 / 0 |
| 80.0 < Ød1 ≤ 120.0 | -0.054 / 0 |
| 120.0 < Ød1 ≤ 180.0 | -0.063 / 0 |
| 180.0 < Ød1 ≤ 250.0 | -0.072 / 0 |
| 250.0 < Ød1 ≤ 315.0 | -0.081 / 0 |
| 315.0 < Ød1 ≤ 400.0 | -0.089 / 0 |
| 400.0 < Ød1 ≤ 500.0 | -0.097 / 0 |

Fixed shaft radius and width

| Height H1 (mm) | Width | | Radius R2 max (mm) |
|-------------------|----------------------|----------------------|-----------------------|
| | L2min (H1 x 0.85) | L1min (H1 x +0.3) | |
| 7.00 | 5.95 | 7.30 | 0.50 |
| 8.00 | 6.80 | 8.30 | |
| 10.00 | 8.50 | 10.30 | |
| 12.00 | 10.30 | 12.30 | |
| 15.00 | 12.75 | 15.30 | 0.70 |
| 20.00 | 17.00 | 20.30 | |

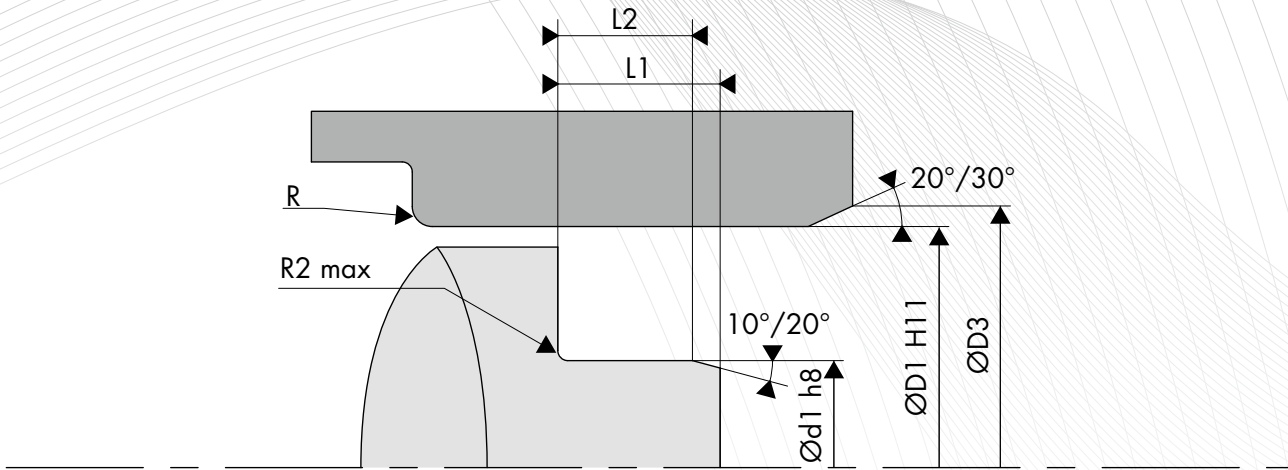

ROTATING HUB DESIGN

Rotating hub hardness

| Rotation speed | Hardness in HRC |
|---------------------------------|-----------------|
| $s \leq 4.0 \text{ m/sec}$ | 45 HRC |
| $4.0 < s \leq 10.0 \text{ m/s}$ | 55 HRC |
| $s > 10.0 \text{ m/sec}$ | 60 HRC |

Surface roughness

| | |
|--------|--------------------------|
| Ra^* | 0.2 to 0.8 μm |
| Rz | 1.0 to 4.0 μm |
| $Rmax$ | $\leq 6.3 \mu\text{m}$ |

* $Ra = 0.1 \mu\text{m}$ for demanding applications

Rotating hub tolerance

| Rotating hub diameter $\text{Ø}D1$ (mm) | Tolerance H11 (mm) |
|---|--------------------|
| $3.0 < \text{Ø}D1 \leq 6.0$ | 0 / +0.075 |
| $6.0 < \text{Ø}D1 \leq 10.0$ | 0 / +0.090 |
| $10.0 < \text{Ø}D1 \leq 18.0$ | 0 / +0.110 |
| $18.0 < \text{Ø}D1 \leq 30.0$ | 0 / +0.130 |
| $30.0 < \text{Ø}D1 \leq 50.0$ | 0 / +0.160 |
| $50.0 < \text{Ø}D1 \leq 80.0$ | 0 / +0.190 |
| $80.0 < \text{Ø}D1 \leq 120.0$ | 0 / +0.220 |
| $120.0 < \text{Ø}D1 \leq 180.0$ | 0 / +0.250 |
| $180.0 < \text{Ø}D1 \leq 250.0$ | 0 / +0.290 |
| $250.0 < \text{Ø}D1 \leq 315.0$ | 0 / +0.320 |
| $315.0 < \text{Ø}D1 \leq 400.0$ | 0 / +0.360 |
| $400.0 < \text{Ø}D1 \leq 500.0$ | 0 / +0.400 |

Chamfer and radius

| Rotating hub diameter $\text{Ø}D1$ (mm) | Chamfer diameter $\text{Ø}D3$ (mm) | Radius R (mm) |
|---|------------------------------------|---------------|
| $\text{Ø}D1 \leq 10.0$ | $\text{Ø}D1 + 1.50$ | 2.00 |
| $10.0 < \text{Ø}D1 \leq 20.0$ | $\text{Ø}D1 + 2.00$ | 2.00 |
| $20.0 < \text{Ø}D1 \leq 30.0$ | $\text{Ø}D1 + 2.50$ | 3.00 |
| $30.0 < \text{Ø}D1 \leq 40.0$ | $\text{Ø}D1 + 3.00$ | 3.00 |
| $40.0 < \text{Ø}D1 \leq 50.0$ | $\text{Ø}D1 + 3.50$ | 4.00 |
| $50.0 < \text{Ø}D1 \leq 70.0$ | $\text{Ø}D1 + 4.00$ | 4.00 |
| $70.0 < \text{Ø}D1 \leq 95.0$ | $\text{Ø}D1 + 4.50$ | 5.00 |
| $95.0 < \text{Ø}D1 \leq 130.0$ | $\text{Ø}D1 + 5.50$ | 6.00 |
| $130.0 < \text{Ø}D1 \leq 240.0$ | $\text{Ø}D1 + 7.00$ | 8.00 |
| $240.0 < \text{Ø}D1 \leq 500.0$ | $\text{Ø}D1 + 11.00$ | 12.00 |

Rotating hub run out

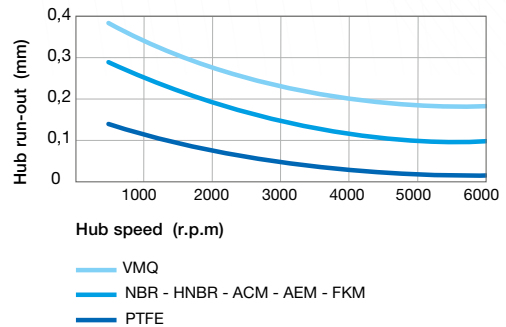

Eccentricity

