

INVERTED SHAFT SEALS OSC



DESCRIPTION

The OSC profile is an inverted shaft seal composed of a single metal cage with a rubber coating and a primary sealing lip with integrated spring.

ADVANTAGES

- Very good static sealing
- Very good thermal expansion compensation
- Greater roughness is allowed in the housing
- Reduced risk of corrosion
- Sealing for low and high viscosity fluids
- Modern primary sealing lip with low radial forces
- Suitable for rotating hubs with a fixed shaft

APPLICATIONS

- All types of rotative applications
- Rotating hubs
- Fixed shafts

MATERIALS

Rubber

- ACM 70 - 75 Shore A
- EPDM 70 - 75 Shore A
- FKM 70 - 75 Shore A
- HNBR 70 - 75 Shore A
- NBR 70 - 75 Shore A

Metal cage

Steel - AISI 1010

Spring

- Steel - AISI 1070 - 1090
- Stainless steel - AISI 316

SEAL DESIGN

Tolerance for the inside diameter of the seal (Ød)

Shaft diameter Ød1 (mm)	Apparent metal cage	Rubber coating	Coating with grooves
Ød1 ≤ 50.0	-0.20 / -0.10	-0.30 / -0.15	-0.40 / -0.20
50.0 < Ød1 ≤ 80.0	-0.23 / -0.13	-0.35 / -0.20	-0.45 / -0.25
80.0 < Ød1 ≤ 120.0	-0.25 / -0.15	-0.35 / -0.20	-0.45 / -0.25
120.0 < Ød1 ≤ 180.0	-0.28 / -0.18	-0.45 / -0.25	-0.55 / -0.30
180.0 < Ød1 ≤ 300.0	-0.30 / -0.20	-0.45 / -0.25	-0.55 / -0.30
300.0 < Ød1 ≤ 500.0	-0.35 / -0.23	-0.55 / -0.30	-0.65 / -0.35

Roundness tolerance

Shaft diameter Ød1 (mm)	Apparent metal cage	Rubber coating
Ød1 ≤ 50.0	0.18	0.25
50.0 < Ød1 ≤ 80.0	0.25	0.35
80.0 < Ød1 ≤ 120.0	0.30	0.50
120.0 < Ød1 ≤ 180.0	0.40	0.65
180.0 < Ød1 ≤ 300.0	0.25% of the inside diameter	0.80
300.0 < Ød1 ≤ 500.0	0.25% of the inside diameter	1.00

Tolerance for the outside diameter of the seal (ØD)

Free and without constraint, the outside diameter of the sealing lip is always bigger than the diameter of the rotating hub. The pre-tightening or interference denotes the difference between these two values. Depending on the hub diameter, the diameter of the sealing lip is generally considered to be greater, between 0.8 and 3.5 mm.

Pumping leads

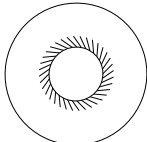
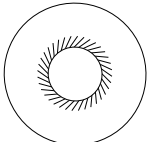
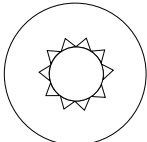
Clockwise	Anti-clockwise	Bi-directional
		
R	L	H0

Other types of pumping leads can be created according to your specifications. Please contact our experts.

TECHNICAL DATA

Speed

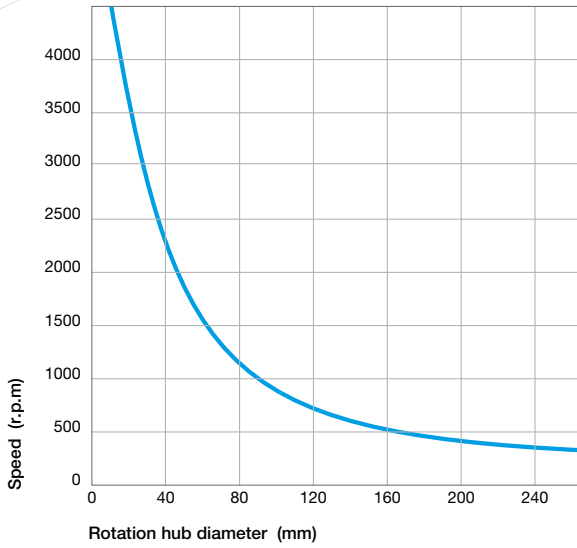

Pressure

The inverted shaft seals are generally used in unpressurised environments, or for pressures between 0.02 and 0.05 MPa (maximum).

Linear speed calculation:

$$s \text{ (m/s)} = \frac{\text{rotating hub } \varnothing \text{ (mm)} \times \text{speed (rpm)} \times \pi}{60,000}$$

Temperature / Media

Media		Maximum temperature depending on the materials						
		ACM	AEM	EPDM	FKM	HNBR	NBR	VMQ
Mineral oils	Oils for motors	+130°C	+130°C	-	+170°C	+130°C	+100°C	+150°C
	Oils for gearboxes	+120°C	+130°C	-	+150°C	+110°C	+80°C	+130°C
	Oils for hypoid gears	+120°C	+130°C	-	+150°C	+110°C	+80°C	-
	ATF oils	+120°C	+130°C	-	+170°C	+130°C	+100°C	-
	Hydraulic oils	+120°C	+130°C	-	+150°C	+130°C	+90°C	-
	Greases	-	+130°C	-	-	+100°C	+90°C	-
Fire-resistant fluids	HFA group - Emulsion with more than 80% water	-	-	-	-	+70°C	+70°C	+60°C
	HFB group - Opposite solution (water in oil)	-	-	-	-	+70°C	+70°C	+60°C
	HFC group - Polymer aqueous solution	-	-	+60°C	-	+70°C	+70°C	-
	HFD group - Water-free synthetic fluids	-	-	-	+150°C	-	-	-
Other fluids	EL + L heating oil	-	-	-	-	+100°C	+90°C	-
	Air	+150°C	+150°C	+150°C	+200°C	+130°C	+100°C	+200°C
	Water	-	-	+150°C	+100°C	+100°C	+90°C	-
	Water for washing	-	-	130°C	100°C	100°C	90°C	-
Temperature range	Min.	-25°C	-40°C	-45°C	-20°C	-30°C	-30°C	-60°C
	Max.	+150°C	+150°C	+150°C	+200°C	+150°C	+100°C	+200°C

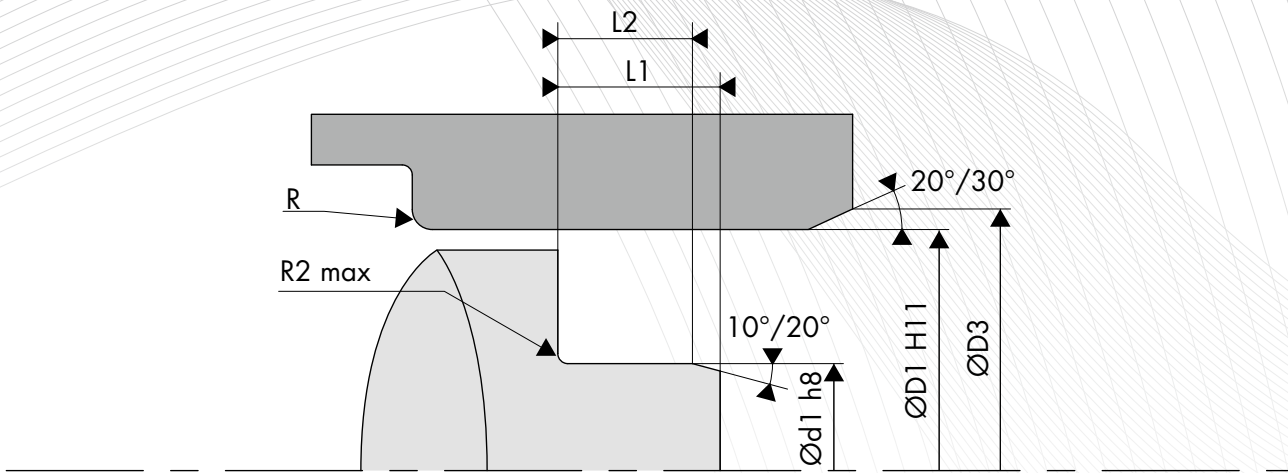

FIXED SHAFT DESIGN

Surface roughness

Ra	1.6 to 6.3 μm
Rz	10.0 to 25.0 μm
Rmax	$\leq 25.0 \mu\text{m}$

Fixed shaft tolerance

Shaft diameter $\varnothing d1$ (mm)	Tolerance $h8$ (mm)
$3.0 < \varnothing d1 \leq 6.0$	-0.018 / 0
$6.0 < \varnothing d1 \leq 10.0$	-0.022 / 0
$10.0 < \varnothing d1 \leq 18.0$	-0.027 / 0
$18.0 < \varnothing d1 \leq 30.0$	-0.033 / 0
$30.0 < \varnothing d1 \leq 50.0$	-0.039 / 0
$50.0 < \varnothing d1 \leq 80.0$	-0.046 / 0
$80.0 < \varnothing d1 \leq 120.0$	-0.054 / 0
$120.0 < \varnothing d1 \leq 180.0$	-0.063 / 0
$180.0 < \varnothing d1 \leq 250.0$	-0.072 / 0
$250.0 < \varnothing d1 \leq 315.0$	-0.081 / 0
$315.0 < \varnothing d1 \leq 400.0$	-0.089 / 0
$400.0 < \varnothing d1 \leq 500.0$	-0.097 / 0

Fixed shaft radius and width

Height $H1$ (mm)	Width		Radius $R2 \text{ max}$ (mm)
	$L2 \text{ min}$ ($H1 \times 0.85$)	$L1 \text{ min}$ ($H1 \times +0.3$)	
7.00	5.95	7.30	0.50
8.00	6.80	8.30	
10.00	8.50	10.30	
12.00	10.30	12.30	
15.00	12.75	15.30	0.70
20.00	17.00	20.30	

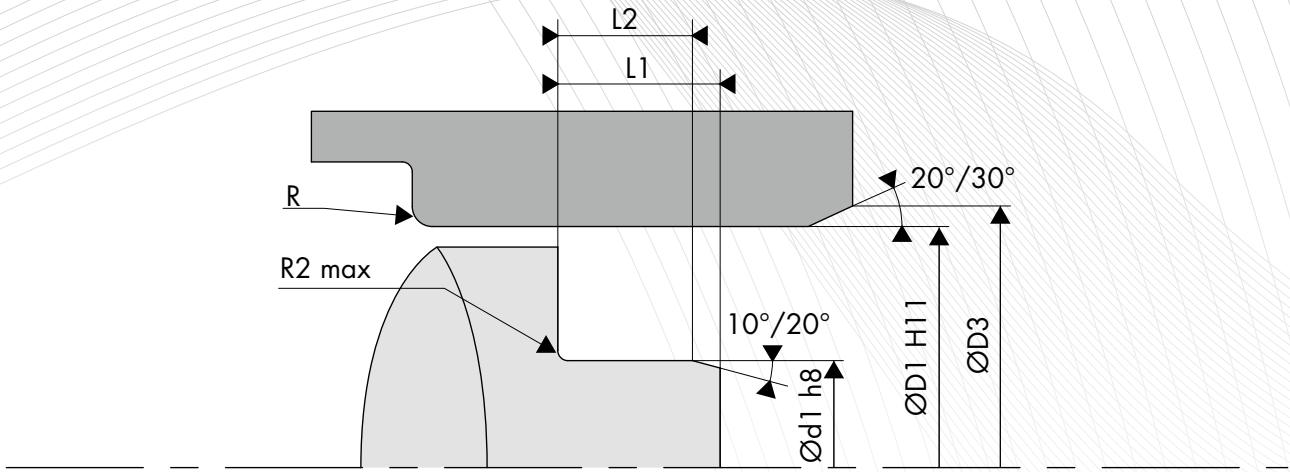

ROTATING HUB DESIGN

Rotating hub hardness

Rotation speed	Hardness in HRC
$s \leq 4.0$ m/sec	45 HRC
$4.0 < s \leq 10.0$ m/s	55 HRC
$s > 10.0$ m/sec	60 HRC

Surface roughness

Ra *	0.2 to 0.8 μ m
Rz	1.0 to 4.0 μ m
Rmax	≤ 6.3 μ m

*Ra = 0.1 μ m for demanding applications

Rotating hub tolerance

Rotating hub diameter ØD1 (mm)	Tolerance H11 (mm)
$\text{ØD1} \leq 3.0$	0 / +0.060
$3.0 < \text{ØD1} \leq 6.0$	0 / +0.075
$6.0 < \text{ØD1} \leq 10.0$	0 / +0.090
$10.0 < \text{ØD1} \leq 18.0$	0 / +0.110
$18.0 < \text{ØD1} \leq 30.0$	0 / +0.130
$30.0 < \text{ØD1} \leq 50.0$	0 / +0.160
$50.0 < \text{ØD1} \leq 80.0$	0 / +0.190
$80.0 < \text{ØD1} \leq 120.0$	0 / +0.220
$120.0 < \text{ØD1} \leq 180.0$	0 / +0.250
$180.0 < \text{ØD1} \leq 250.0$	0 / +0.290
$250.0 < \text{ØD1} \leq 315.0$	0 / +0.320
$315.0 < \text{ØD1} \leq 400.0$	0 / +0.360
$400.0 < \text{ØD1} \leq 500.0$	0 / +0.400

Chamfer and radius

Rotating hub diameter ØD1 (mm)	Chamfer diameter ØD3 (mm)	Radius R (mm)
$\text{ØD1} \leq 10.0$	$\text{ØD1} + 1.50$	2.00
$10.0 < \text{ØD1} \leq 20.0$	$\text{ØD1} + 2.00$	2.00
$20.0 < \text{ØD1} \leq 30.0$	$\text{ØD1} + 2.50$	3.00
$30.0 < \text{ØD1} \leq 40.0$	$\text{ØD1} + 3.00$	3.00
$40.0 < \text{ØD1} \leq 50.0$	$\text{ØD1} + 3.50$	4.00
$50.0 < \text{ØD1} \leq 70.0$	$\text{ØD1} + 4.00$	4.00
$70.0 < \text{ØD1} \leq 95.0$	$\text{ØD1} + 4.50$	5.00
$95.0 < \text{ØD1} \leq 130.0$	$\text{ØD1} + 5.50$	6.00
$130.0 < \text{ØD1} \leq 240.0$	$\text{ØD1} + 7.00$	8.00
$240.0 < \text{ØD1} \leq 500.0$	$\text{ØD1} + 11.00$	12.00

Rotating hub run out

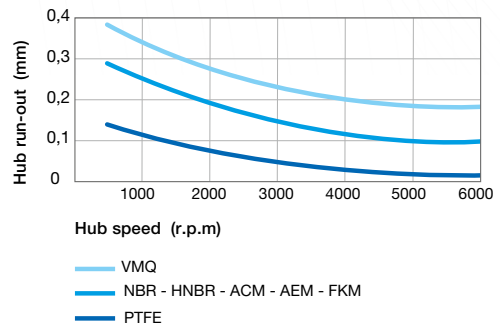

Eccentricity

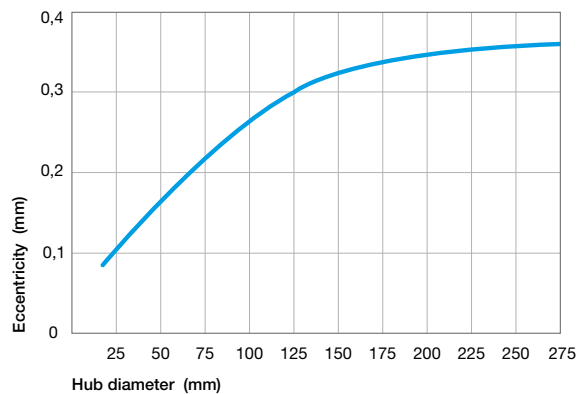

○ DIMENSIONS

Part number	Shaft diameter Ød1 h8	Bore diameter ØD1 H11	Seal height H1
OSC 25 x 35 x 7	25.00	35.00	7.00
OSC 35 x 50 x 7	35.00	50.00	7.00
OSC 42 x 56 x 8	42.00	56.00	8.00
OSC 52 x 80 x 13	52.00	80.00	13.00
OSC 55 x 67 x 8	55.00	67.00	8.00
OSC 57 x 73 x 7	57.00	73.00	7.00
OSC 60 x 78 x 8	60.00	78.00	8.00
OSC 65 x 78 x 8	65.00	78.00	8.00
OSC 65 x 85 x 11	65.00	85.00	11.00
OSC 65 x 88 x 12	65.00	88.00	12.00
OSC 76 x 122 x 11	76.00	122.00	11.00
OSC 95 x 115 x 13	95.00	115.00	13.00
OSC 95 x 120 x 13	95.00	120.00	13.00

Part number	Shaft diameter Ød1 h8	Bore diameter ØD1 H11	Seal height H1
OSC 108 x 145 x 12.5	108.00	145.00	12.50
OSC 108 x 160 x 7	108.00	160.00	7.00
OSC 114 x 165 x 13	114.00	165.00	13.00
OSC 115 x 140 x 13	115.00	140.00	13.00
OSC 120 x 150 x 14	120.00	150.00	14.00
OSC 124 x 170 x 14.5	124.00	170.00	14.50
OSC 130 x 160 x 13	130.00	160.00	13.00
OSC 130 x 160 x 14	130.00	160.00	14.00
OSC 130 x 162 x 15	130.00	162.00	15.00
OSC 130 x 172 x 11	130.00	172.00	11.00
OSC 145 x 174 x 14	145.00	174.00	14.00
OSC 150 x 180 x 14	150.00	180.00	14.00