

INVERTED SHAFT SEALS

OTBC

DESCRIPTION

The OTBC profile is an inverted shaft seal composed of a single internal metal cage with a rubber coating covering half of the outside of the cage, a primary sealing lip with an integrated spring and an additional anti-pollution lip.

ADVANTAGES

Good radial rigidity, particularly for large diameters

Good stability when assembled, preventing the bounce-back effect

Good static sealing

Good thermal expansion compensation

Good heat transfer

Sealing for low and high viscosity fluids

Modern primary sealing lip with low radial forces

Protection against undesirable air contaminants

Suitable for rotating hubs with a fixed shaft

APPLICATIONS

All types of rotative applications

Rotating hubs

Fixed shafts

MATERIALS

Rubber

ACM 70 - 75 Shore A

EPDM 70 - 75 Shore A

FKM 70 - 75 Shore A

HNBR 70 - 75 Shore A

NBR 70 - 75 Shore A

Metal cage

Steel - AISI 1010

Stainless steel - AISI 304

Stainless steel - AISI 316

Spring

Steel - AISI 1070 - 1090

Stainless steel - AISI 316

SEAL DESIGN

Tolerance for the inside diameter of the seal (Ød)

Shaft diameter Ød1 (mm)	Apparent metal cage	Rubber coating	Coating with grooves
Ød1 ≤ 50.0	-0.20 / -0.10	-0.30 / -0.15	-0.40 / -0.20
50.0 < Ød1 ≤ 80.0	-0.23 / -0.13	-0.35 / -0.20	-0.45 / -0.25
80.0 < Ød1 ≤ 120.0	-0.25 / -0.15	-0.35 / -0.20	-0.45 / -0.25
120.0 < Ød1 ≤ 180.0	-0.28 / -0.18	-0.45 / -0.25	-0.55 / -0.30
180.0 < Ød1 ≤ 300.0	-0.30 / -0.20	-0.45 / -0.25	-0.55 / -0.30
300.0 < Ød1 ≤ 500.0	-0.35 / -0.23	-0.55 / -0.30	-0.65 / -0.35

Roundness tolerance

Shaft diameter Ød1 (mm)	Apparent metal cage	Rubber coating
Ød1 ≤ 50.0	0.18	0.25
50.0 < Ød1 ≤ 80.0	0.25	0.35
80.0 < Ød1 ≤ 120.0	0.30	0.50
120.0 < Ød1 ≤ 180.0	0.40	0.65
180.0 < Ød1 ≤ 300.0	0.25% of the inside diameter	0.80
300.0 < Ød1 ≤ 500.0	0.25% of the inside diameter	1.00

Tolerance for the outside diameter of the seal (ØD)

Free and without constraint, the outside diameter of the sealing lip is always bigger than the diameter of the rotating hub. The pre-tightening or interference denotes the difference between these two values. Depending on the hub diameter, the diameter of the sealing lip is generally considered to be greater, between 0.8 and 3.5 mm.

Pumping leads

Clockwise	Anti-clockwise	Bi-directional
R	L	H0

Other types of pumping leads can be created according to your specifications. Please contact our experts.

TECHNICAL DATA

Speed

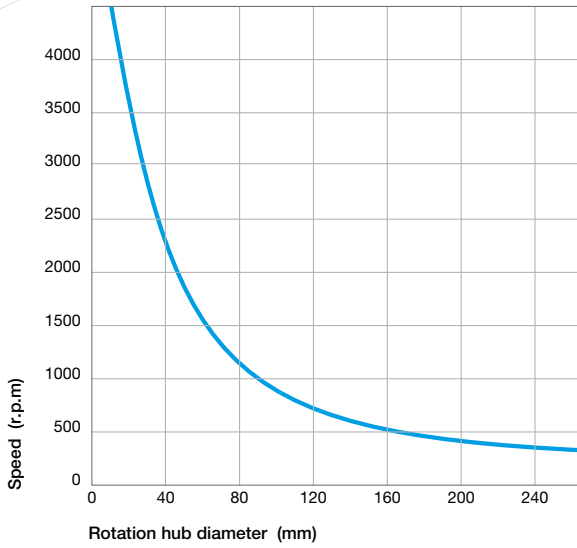

Pressure

The inverted shaft seals are generally used in unpressurised environments, or for pressures between 0.02 and 0.05 MPa (maximum).

Linear speed calculation:

$$s \text{ (m/s)} = \frac{\text{rotating hub } \varnothing \text{ (mm)} \times \text{speed (rpm)} \times \pi}{60,000}$$

Temperature / Media

Media		Maximum temperature depending on the materials						
		ACM	AEM	EPDM	FKM	HNBR	NBR	VMQ
Mineral oils	Oils for motors	+130°C	+130°C	-	+170°C	+130°C	+100°C	+150°C
	Oils for gearboxes	+120°C	+130°C	-	+150°C	+110°C	+80°C	+130°C
	Oils for hypoid gears	+120°C	+130°C	-	+150°C	+110°C	+80°C	-
	ATF oils	+120°C	+130°C	-	+170°C	+130°C	+100°C	-
	Hydraulic oils	+120°C	+130°C	-	+150°C	+130°C	+90°C	-
	Greases	-	+130°C	-	-	+100°C	+90°C	-
Fire-resistant fluids	HFA group - Emulsion with more than 80% water	-	-	-	-	+70°C	+70°C	+60°C
	HFB group - Opposite solution (water in oil)	-	-	-	-	+70°C	+70°C	+60°C
	HFC group - Polymer aqueous solution	-	-	+60°C	-	+70°C	+70°C	-
	HFD group - Water-free synthetic fluids	-	-	-	+150°C	-	-	-
Other fluids	EL + L heating oil	-	-	-	-	+100°C	+90°C	-
	Air	+150°C	+150°C	+150°C	+200°C	+130°C	+100°C	+200°C
	Water	-	-	+150°C	+100°C	+100°C	+90°C	-
	Water for washing	-	-	+130°C	+100°C	+100°C	+90°C	-
Temperature range	Min.	-25°C	-40°C	-45°C	-20°C	-30°C	-30°C	-60°C
	Max.	+150°C	+150°C	+150°C	+200°C	+150°C	+100°C	+200°C

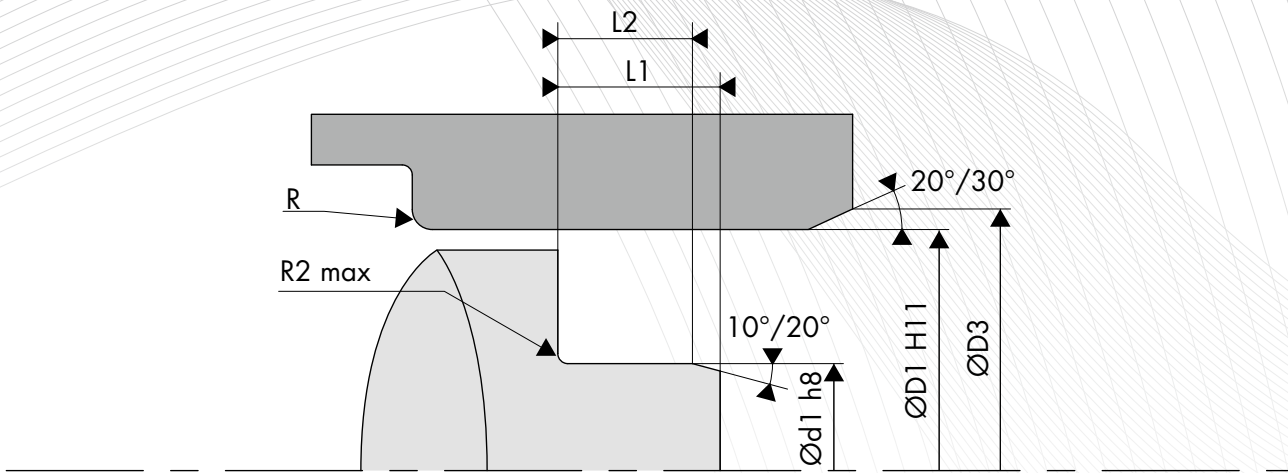

FIXED SHAFT DESIGN

Surface roughness

Ra	0.8 to 3.2 µm
Rz	6.3 to 16.0 µm
Rmax	≤16.0 µm

Fixed shaft tolerance

Shaft diameter Ød1 (mm)	Tolerance h8 (mm)
3.0 < Ød1 ≤ 6.0	-0.018 / 0
6.0 < Ød1 ≤ 10.0	-0.022 / 0
10.0 < Ød1 ≤ 18.0	-0.027 / 0
18.0 < Ød1 ≤ 30.0	-0.033 / 0
30.0 < Ød1 ≤ 50.0	-0.039 / 0
50.0 < Ød1 ≤ 80.0	-0.046 / 0
80.0 < Ød1 ≤ 120.0	-0.054 / 0
120.0 < Ød1 ≤ 180.0	-0.063 / 0
180.0 < Ød1 ≤ 250.0	-0.072 / 0
250.0 < Ød1 ≤ 315.0	-0.081 / 0
315.0 < Ød1 ≤ 400.0	-0.089 / 0
400.0 < Ød1 ≤ 500.0	-0.097 / 0

Fixed shaft radius and width

Height H1 (mm)	Width		Radius R2 max (mm)
	L2min (H1 x 0.85)	L1min (H1 x +0.3)	
7.00	5.95	7.30	0.50
8.00	6.80	8.30	
10.00	8.50	10.30	
12.00	10.30	12.30	
15.00	12.75	15.30	0.70
20.00	17.00	20.30	

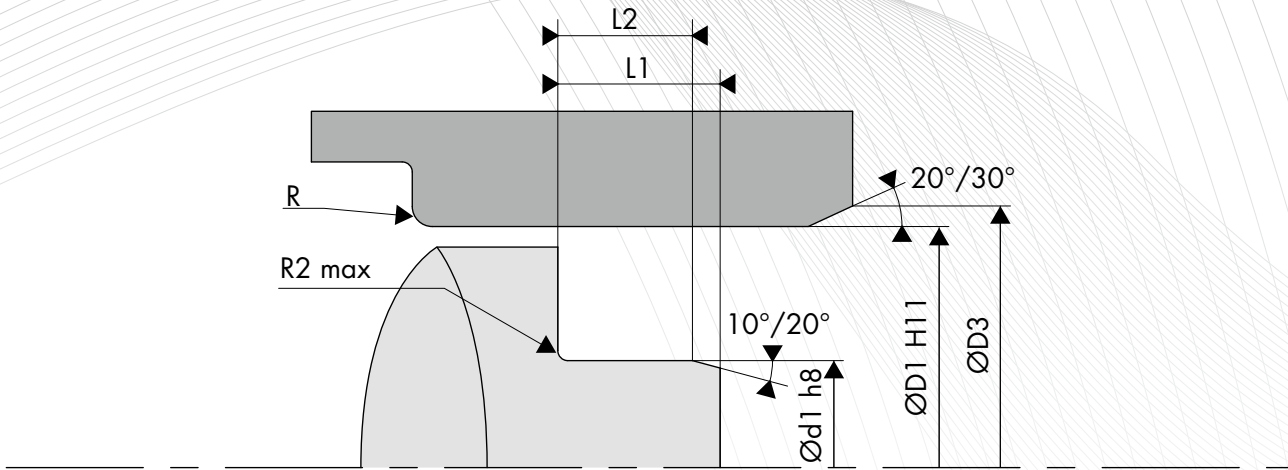

○ ROTATING HUB DESIGN

Rotating hub hardness

Rotation speed	Hardness in HRC
$s \leq 4.0$ m/sec	45 HRC
$4.0 < s \leq 10.0$ m/s	55 HRC
$s > 10.0$ m/sec	60 HRC

Surface roughness

Ra *	0.2 to 0.8 μm
Rz	1.0 to 4.0 μm
Rmax	≤ 6.3 μm

*Ra = 0.1 μm for demanding applications

Rotating hub tolerance

Rotating hub diameter $\text{Ø}D1$ (mm)	Tolerance H11 (mm)
$3.0 < \text{Ø}D1 \leq 6.0$	0 / +0.075
$6.0 < \text{Ø}D1 \leq 10.0$	0 / +0.090
$10.0 < \text{Ø}D1 \leq 18.0$	0 / +0.110
$18.0 < \text{Ø}D1 \leq 30.0$	0 / +0.130
$30.0 < \text{Ø}D1 \leq 50.0$	0 / +0.160
$50.0 < \text{Ø}D1 \leq 80.0$	0 / +0.190
$80.0 < \text{Ø}D1 \leq 120.0$	0 / +0.220
$120.0 < \text{Ø}D1 \leq 180.0$	0 / +0.250
$180.0 < \text{Ø}D1 \leq 250.0$	0 / +0.290
$250.0 < \text{Ø}D1 \leq 315.0$	0 / +0.320
$315.0 < \text{Ø}D1 \leq 400.0$	0 / +0.360
$400.0 < \text{Ø}D1 \leq 500.0$	0 / +0.400

Chamfer and radius

Rotating hub diameter $\text{Ø}D1$ (mm)	Chamfer diameter $\text{Ø}D3$ (mm)	Radius R (mm)
$\text{Ø}D1 \leq 10.0$	$\text{Ø}D1 + 1.50$	2.00
$10.0 < \text{Ø}D1 \leq 20.0$	$\text{Ø}D1 + 2.00$	2.00
$20.0 < \text{Ø}D1 \leq 30.0$	$\text{Ø}D1 + 2.50$	3.00
$30.0 < \text{Ø}D1 \leq 40.0$	$\text{Ø}D1 + 3.00$	3.00
$40.0 < \text{Ø}D1 \leq 50.0$	$\text{Ø}D1 + 3.50$	4.00
$50.0 < \text{Ø}D1 \leq 70.0$	$\text{Ø}D1 + 4.00$	4.00
$70.0 < \text{Ø}D1 \leq 95.0$	$\text{Ø}D1 + 4.50$	5.00
$95.0 < \text{Ø}D1 \leq 130.0$	$\text{Ø}D1 + 5.50$	6.00
$130.0 < \text{Ø}D1 \leq 240.0$	$\text{Ø}D1 + 7.00$	8.00
$240.0 < \text{Ø}D1 \leq 500.0$	$\text{Ø}D1 + 11.00$	12.00

Rotating hub run out

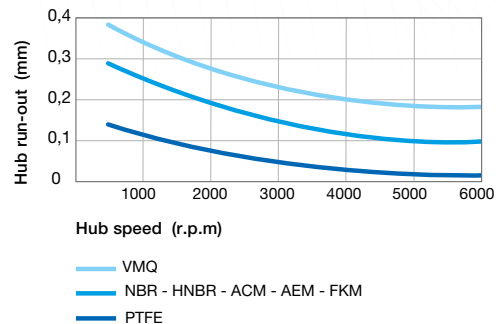

Eccentricity

