

INVERTED SHAFT SEALS

OVA2

DESCRIPTION

The OVA2 profile is an inverted shaft seal composed of a single internal metal cage with a metal reinforcement and a primary sealing lip without a spring.

ADVANTAGES

Excellent radial rigidity, particularly for large diameters

Very good stability when assembled, preventing the bounce-back effect

Sealing for high viscosity fluids

Primary sealing lip generating low levels of friction and heat

Suitable for rotating hubs with a fixed shaft

APPLICATIONS

All types of rotative applications

Rotating hubs

Fixed shafts

MATERIALS

Rubber

ACM 70 - 75 Shore A

EPDM 70 - 75 Shore A

FKM 70 - 75 Shore A

HNBR 70 - 75 Shore A

NBR 70 - 75 Shore A

Metal cage

Steel - AISI 1010

Stainless steel - AISI 304

Stainless steel - AISI 316

SEAL DESIGN

Tolerance for the inside diameter of the seal ($\varnothing d$)

Shaft diameter $\varnothing d1$ (mm)	Apparent metal cage	Rubber coating	Coating with grooves
$\varnothing d1 \leq 50.0$	-0.20 / -0.10	-0.30 / -0.15	-0.40 / -0.20
$50.0 < \varnothing d1 \leq 80.0$	-0.23 / -0.13	-0.35 / -0.20	-0.45 / -0.25
$80.0 < \varnothing d1 \leq 120.0$	-0.25 / -0.15	-0.35 / -0.20	-0.45 / -0.25
$120.0 < \varnothing d1 \leq 180.0$	-0.28 / -0.18	-0.45 / -0.25	-0.55 / -0.30
$180.0 < \varnothing d1 \leq 300.0$	-0.30 / -0.20	-0.45 / -0.25	-0.55 / -0.30
$300.0 < \varnothing d1 \leq 500.0$	-0.35 / -0.23	-0.55 / -0.30	-0.65 / -0.35

Roundness tolerance

Shaft diameter $\varnothing d1$ (mm)	Apparent metal cage	Rubber coating
$\varnothing d1 \leq 50.0$	0.18	0.25
$50.0 < \varnothing d1 \leq 80.0$	0.25	0.35
$80.0 < \varnothing d1 \leq 120.0$	0.30	0.50
$120.0 < \varnothing d1 \leq 180.0$	0.40	0.65
$180.0 < \varnothing d1 \leq 300.0$	0.25% of the inside diameter	0.80
$300.0 < \varnothing d1 \leq 500.0$	0.25% of the inside diameter	1.00

Tolerance for the outside diameter of the seal ($\varnothing D$)

Free and without constraint, the outside diameter of the sealing lip is always bigger than the diameter of the rotating hub. The pre-tightening or interference denotes the difference between these two values. Depending on the hub diameter, the diameter of the sealing lip is generally considered to be greater, between 0.8 and 3.5 mm.

TECHNICAL DATA

Speed

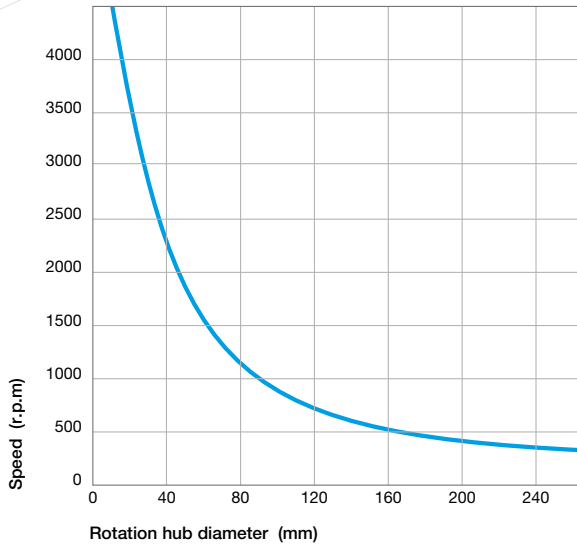

Linear speed calculation:

$$s \text{ (m/s)} = \frac{\text{rotating hub } \varnothing \text{ (mm)} \times \text{speed (rpm)} \times \pi}{60,000}$$

Pressure

Inverted shaft seals with a primary sealing lip and no spring are used only in pressurised environments.

We recommend using inverted shaft seals with springs for use in pressurised environments between 0.02 and 0.05 MPa (max).

Temperature / Media

Media		Maximum temperature depending on the materials						
		ACM	AEM	EPDM	FKM	HNBR	NBR	VMQ
Mineral oils	Oils for motors	+130°C	+130°C	-	+170°C	+130°C	+100°C	+150°C
	Oils for gearboxes	+120°C	+130°C	-	+150°C	+110°C	+80°C	+130°C
	Oils for hypoid gears	+120°C	+130°C	-	+150°C	+110°C	+80°C	-
	ATF oils	+120°C	+130°C	-	+170°C	+130°C	+100°C	-
	Hydraulic oils	+120°C	+130°C	-	+150°C	+130°C	+90°C	-
	Greases	-	+130°C	-	-	+100°C	+90°C	-
Fire-resistant fluids	HFA group - Emulsion with more than 80% water	-	-	-	-	+70°C	+70°C	+60°C
	HFB group - Opposite solution (water in oil)	-	-	-	-	+70°C	+70°C	+60°C
	HFC group - Polymer aqueous solution	-	-	+60°C	-	+70°C	+70°C	-
	HFD group - Water-free synthetic fluids	-	-	-	+150°C	-	-	-
Other fluids	EL + L heating oil	-	-	-	-	+100°C	+90°C	-
	Air	+150°C	+150°C	+150°C	+200°C	+130°C	+100°C	+200°C
	Water	-	-	+150°C	+100°C	+100°C	+90°C	-
	Water for washing	-	-	+130°C	+100°C	+100°C	+90°C	-
Temperature range	Min.	-25°C	-40°C	-45°C	-20°C	-30°C	-30°C	-60°C
	Max.	+150°C	+150°C	+150°C	+200°C	+150°C	+100°C	+200°C

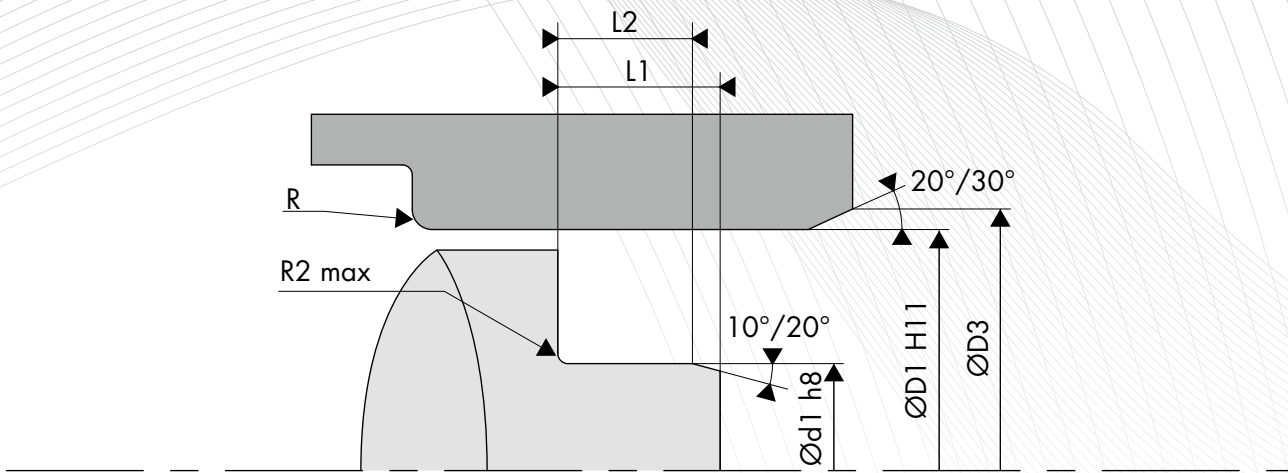

FIXED SHAFT DESIGN

Surface roughness

Ra	0.8 to 3.2 μm
Rz	6.3 to 16.0 μm
Rmax	$\leq 16.0 \mu\text{m}$

Fixed shaft tolerance

Shaft diameter $\varnothing d1$ (mm)	Tolerance $h8$ (mm)
$3.0 < \varnothing d1 \leq 6.0$	-0.018 / 0
$6.0 < \varnothing d1 \leq 10.0$	-0.022 / 0
$10.0 < \varnothing d1 \leq 18.0$	-0.027 / 0
$18.0 < \varnothing d1 \leq 30.0$	-0.033 / 0
$30.0 < \varnothing d1 \leq 50.0$	-0.039 / 0
$50.0 < \varnothing d1 \leq 80.0$	-0.046 / 0
$80.0 < \varnothing d1 \leq 120.0$	-0.054 / 0
$120.0 < \varnothing d1 \leq 180.0$	-0.063 / 0
$180.0 < \varnothing d1 \leq 250.0$	-0.072 / 0
$250.0 < \varnothing d1 \leq 315.0$	-0.081 / 0
$315.0 < \varnothing d1 \leq 400.0$	-0.089 / 0
$400.0 < \varnothing d1 \leq 500.0$	-0.097 / 0

Fixed shaft radius and width

Height $H1$ (mm)	Width		Radius $R2 \text{ max}$ (mm)
	$L2 \text{ min}$ ($H1 \times 0.85$)	$L1 \text{ min}$ ($H1 \times +0.3$)	
7.00	5.95	7.30	0.50
8.00	6.80	8.30	
10.00	8.50	10.30	
12.00	10.30	12.30	
15.00	12.75	15.30	0.70
20.00	17.00	20.30	

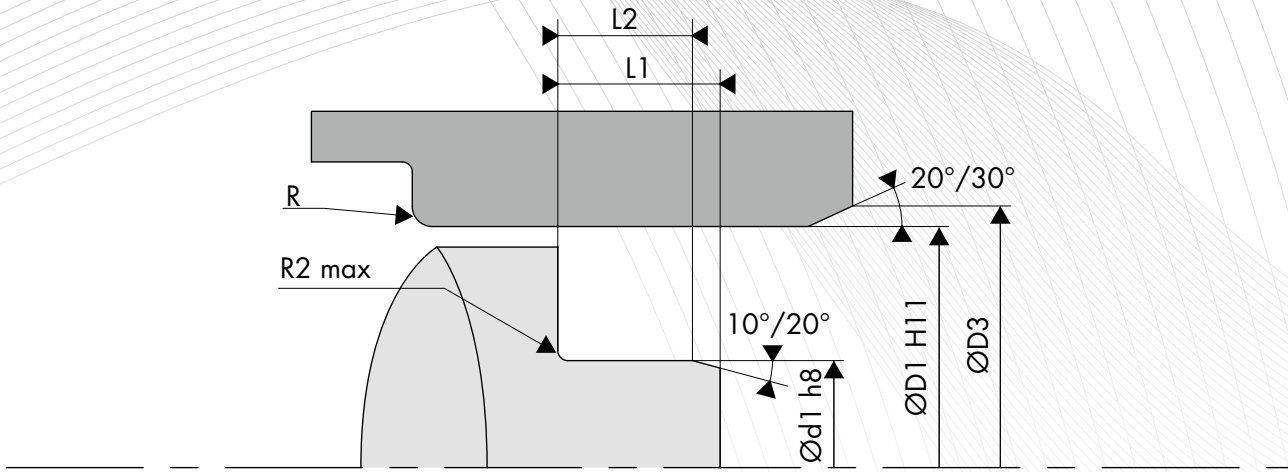

○ ROTATING HUB DESIGN

Rotating hub hardness

Rotation speed	Hardness in HRC
$s \leq 4.0\ \text{m/sec}$	45 HRC
$4.0 < s \leq 10.0\ \text{m/s}$	55 HRC
$s > 10.0\ \text{m/sec}$	60 HRC

Surface roughness

Ra^*	0.2 to 0.8 μm
Rz	1.0 to 4.0 μm
$Rmax$	$\leq 6.3\ \mu\text{m}$

* $Ra = 0.1\ \mu\text{m}$ for demanding applications

Rotating hub tolerance

Rotating hub diameter $\text{Ø}D1$ (mm)	Tolerance H11 (mm)
$3.0 < \text{Ø}D1 \leq 6.0$	0 / +0.075
$6.0 < \text{Ø}D1 \leq 10.0$	0 / +0.090
$10.0 < \text{Ø}D1 \leq 18.0$	0 / +0.110
$18.0 < \text{Ø}D1 \leq 30.0$	0 / +0.130
$30.0 < \text{Ø}D1 \leq 50.0$	0 / +0.160
$50.0 < \text{Ø}D1 \leq 80.0$	0 / +0.190
$80.0 < \text{Ø}D1 \leq 120.0$	0 / +0.220
$120.0 < \text{Ø}D1 \leq 180.0$	0 / +0.250
$180.0 < \text{Ø}D1 \leq 250.0$	0 / +0.290
$250.0 < \text{Ø}D1 \leq 315.0$	0 / +0.320
$315.0 < \text{Ø}D1 \leq 400.0$	0 / +0.360
$400.0 < \text{Ø}D1 \leq 500.0$	0 / +0.400

Chamfer and radius

Rotating hub diameter $\text{Ø}D1$ (mm)	Chamfer diameter $\text{Ø}D3$ (mm)	Radius R (mm)
$\text{Ø}D1 \leq 10.0$	$\text{Ø}D1 + 1.50$	2.00
$10.0 < \text{Ø}D1 \leq 20.0$	$\text{Ø}D1 + 2.00$	2.00
$20.0 < \text{Ø}D1 \leq 30.0$	$\text{Ø}D1 + 2.50$	3.00
$30.0 < \text{Ø}D1 \leq 40.0$	$\text{Ø}D1 + 3.00$	3.00
$40.0 < \text{Ø}D1 \leq 50.0$	$\text{Ø}D1 + 3.50$	4.00
$50.0 < \text{Ø}D1 \leq 70.0$	$\text{Ø}D1 + 4.00$	4.00
$70.0 < \text{Ø}D1 \leq 95.0$	$\text{Ø}D1 + 4.50$	5.00
$95.0 < \text{Ø}D1 \leq 130.0$	$\text{Ø}D1 + 5.50$	6.00
$130.0 < \text{Ø}D1 \leq 240.0$	$\text{Ø}D1 + 7.00$	8.00
$240.0 < \text{Ø}D1 \leq 500.0$	$\text{Ø}D1 + 11.00$	12.00

Rotating hub run out and eccentricity

