

## INVERTED SHAFT SEALS

# OVBR

### DESCRIPTION

The OVBR profile is an inverted shaft seal composed of a single internal metal cage with a rubber coating on the outside and the end of the cage, and a primary sealing lip without a spring.

### ADVANTAGES

Good radial rigidity, particularly for large diameters

Good stability when assembled, preventing the bounce-back effect

Improved static sealing

Good thermal expansion compensation

Good heat transfer

Sealing for high viscosity fluids

Primary sealing lip generating low levels of friction and heat

### APPLICATIONS

All types of rotative applications

Rotating hubs

Fixed shafts

### MATERIALS

#### Rubber

ACM 70 - 75 Shore A

EPDM 70 - 75 Shore A

FKM 70 - 75 Shore A

HNBR 70 - 75 Shore A

NBR 70 - 75 Shore A

#### Metal cage

Steel - AISI 1010

Stainless steel - AISI 304

Stainless steel - AISI 316

### SEAL DESIGN

#### Tolerance for the inside diameter of the seal ( $\varnothing d$ )

Shaft diameter $\varnothing d1$ (mm)	Apparent metal cage	Rubber coating	Coating with grooves
$\varnothing d1 \leq 50.0$	-0.20 / -0.10	-0.30 / -0.15	-0.40 / -0.20
$50.0 < \varnothing d1 \leq 80.0$	-0.23 / -0.13	-0.35 / -0.20	-0.45 / -0.25
$80.0 < \varnothing d1 \leq 120.0$	-0.25 / -0.15	-0.35 / -0.20	-0.45 / -0.25
$120.0 < \varnothing d1 \leq 180.0$	-0.28 / -0.18	-0.45 / -0.25	-0.55 / -0.30
$180.0 < \varnothing d1 \leq 300.0$	-0.30 / -0.20	-0.45 / -0.25	-0.55 / -0.30
$300.0 < \varnothing d1 \leq 500.0$	-0.35 / -0.23	-0.55 / -0.30	-0.65 / -0.35

#### Roundness tolerance

Shaft diameter $\varnothing d1$ (mm)	Apparent metal cage	Rubber coating
$\varnothing d1 \leq 50.0$	0.18	0.25
$50.0 < \varnothing d1 \leq 80.0$	0.25	0.35
$80.0 < \varnothing d1 \leq 120.0$	0.30	0.50
$120.0 < \varnothing d1 \leq 180.0$	0.40	0.65
$180.0 < \varnothing d1 \leq 300.0$	0.25% of the inside diameter	0.80
$300.0 < \varnothing d1 \leq 500.0$	0.25% of the inside diameter	1.00

#### Tolerance for the outside diameter of the seal ( $\varnothing D$ )

Free and without constraint, the outside diameter of the sealing lip is always bigger than the diameter of the rotating hub. The pre-tightening or interference denotes the difference between these two values. Depending on the hub diameter, the diameter of the sealing lip is generally considered to be greater, between 0.8 and 3.5 mm.

**TECHNICAL DATA**

**Speed**

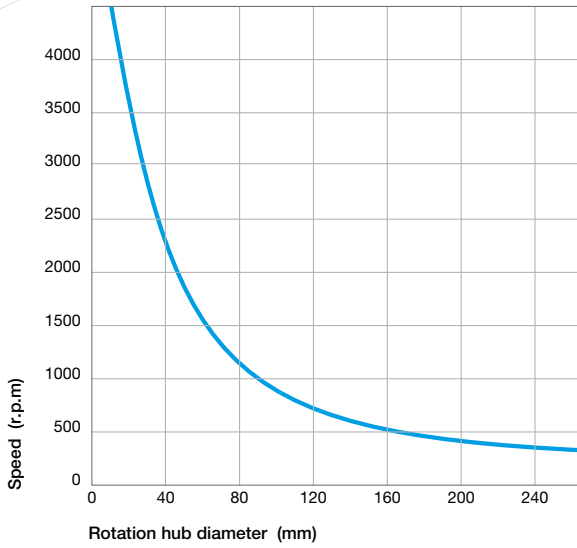

Linear speed calculation:

$$s \text{ (m/s)} = \frac{\text{rotating hub } \varnothing \text{ (mm)} \times \text{speed (rpm)} \times \pi}{60,000}$$

**Pressure**

**Inverted shaft seals with a primary sealing lip and no spring are used only in pressurised environments.**

We recommend using inverted shaft seals with springs for use in pressurised environments between 0.02 and 0.05 MPa (max).

**Temperature / Media**

Media		Maximum temperature depending on the materials						
		ACM	AEM	EPDM	FKM	HNBR	NBR	VMQ
Mineral oils	Oils for motors	+130°C	+130°C	-	+170°C	+130°C	+100°C	+150°C
	Oils for gearboxes	+120°C	+130°C	-	+150°C	+110°C	+80°C	+130°C
	Oils for hypoid gears	+120°C	+130°C	-	+150°C	+110°C	+80°C	-
	ATF oils	+120°C	+130°C	-	+170°C	+130°C	+100°C	-
	Hydraulic oils	+120°C	+130°C	-	+150°C	+130°C	+90°C	-
	Greases	-	+130°C	-	-	+100°C	+90°C	-
Fire-resistant fluids	HFA group - Emulsion with more than 80% water	-	-	-	-	+70°C	+70°C	+60°C
	HFB group - Opposite solution (water in oil)	-	-	-	-	+70°C	+70°C	+60°C
	HFC group - Polymer aqueous solution	-	-	+60°C	-	+70°C	+70°C	-
	HFD group - Water-free synthetic fluids	-	-	-	+150°C	-	-	-
Other fluids	EL + L heating oil	-	-	-	-	+100°C	+90°C	-
	Air	+150°C	+150°C	+150°C	+200°C	+130°C	+100°C	+200°C
	Water	-	-	+150°C	+100°C	+100°C	+90°C	-
	Water for washing	-	-	+130°C	+100°C	+100°C	+90°C	-
Temperature range	Min.	-25°C	-40°C	-45°C	-20°C	-30°C	-30°C	-60°C
	Max.	+150°C	+150°C	+150°C	+200°C	+150°C	+100°C	+200°C

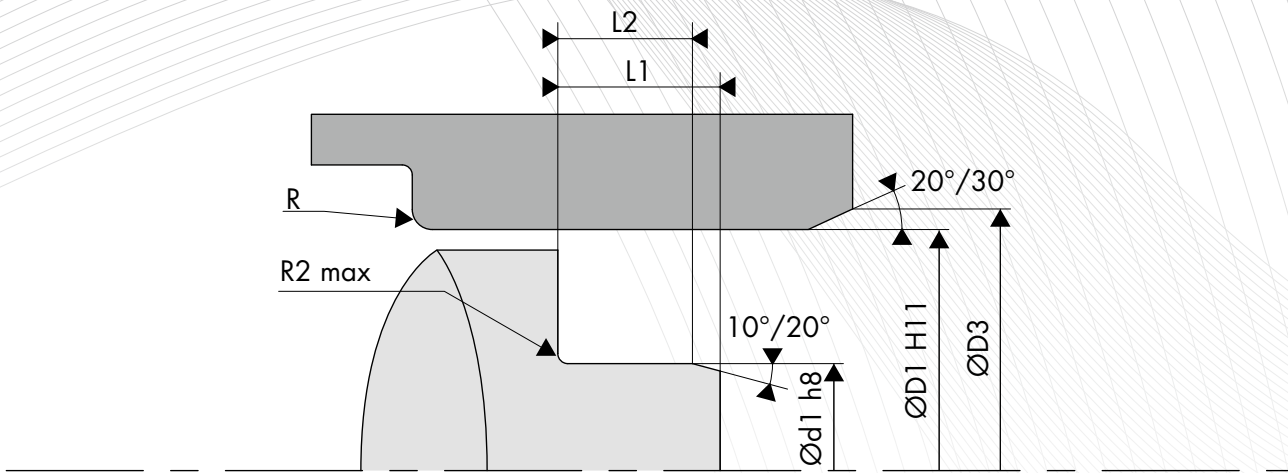

## FIXED SHAFT DESIGN

### Surface roughness

Ra	0.8 to 3.2 $\mu\text{m}$
Rz	6.3 to 16.0 $\mu\text{m}$
Rmax	$\leq 16.0 \mu\text{m}$

### Fixed shaft tolerance

Shaft diameter $\varnothing d1$ (mm)	Tolerance $h8$ (mm)
$3.0 < \varnothing d1 \leq 6.0$	-0.018 / 0
$6.0 < \varnothing d1 \leq 10.0$	-0.022 / 0
$10.0 < \varnothing d1 \leq 18.0$	-0.027 / 0
$18.0 < \varnothing d1 \leq 30.0$	-0.033 / 0
$30.0 < \varnothing d1 \leq 50.0$	-0.039 / 0
$50.0 < \varnothing d1 \leq 80.0$	-0.046 / 0
$80.0 < \varnothing d1 \leq 120.0$	-0.054 / 0
$120.0 < \varnothing d1 \leq 180.0$	-0.063 / 0
$180.0 < \varnothing d1 \leq 250.0$	-0.072 / 0
$250.0 < \varnothing d1 \leq 315.0$	-0.081 / 0
$315.0 < \varnothing d1 \leq 400.0$	-0.089 / 0
$400.0 < \varnothing d1 \leq 500.0$	-0.097 / 0

### Fixed shaft radius and width

Height $H1$ (mm)	Width		Radius $R2 \text{ max}$ (mm)
	$L2 \text{ min}$ ( $H1 \times 0.85$ )	$L1 \text{ min}$ ( $H1 \times +0.3$ )	
7.00	5.95	7.30	0.50
8.00	6.80	8.30	
10.00	8.50	10.30	
12.00	10.30	12.30	
15.00	12.75	15.30	0.70
20.00	17.00	20.30	

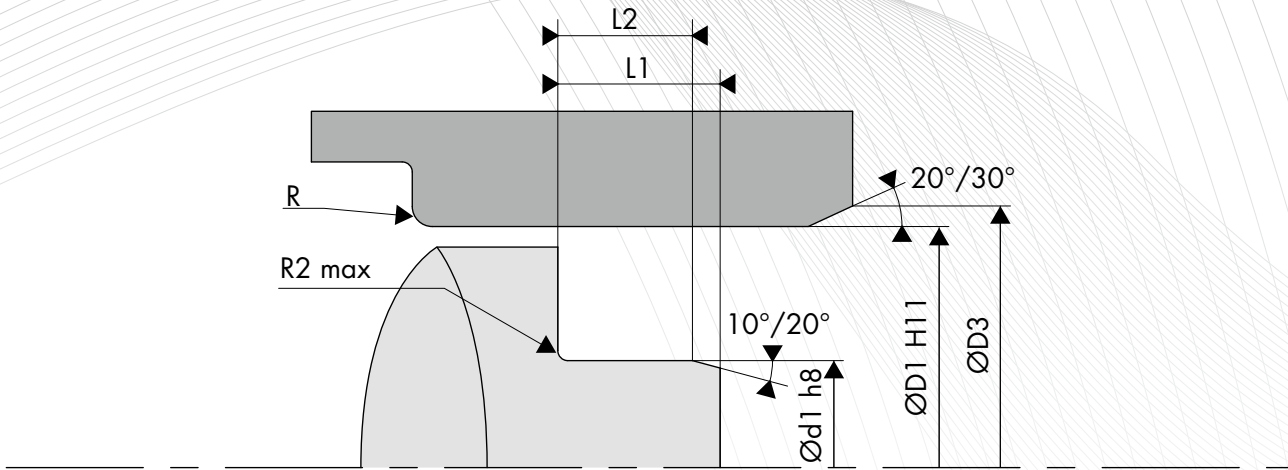

## ○ ROTATING HUB DESIGN

### Rotating hub hardness

Rotation speed	Hardness in HRC
$s \leq 4.0\ \text{m/sec}$	45 HRC
$4.0 < s \leq 10.0\ \text{m/s}$	55 HRC
$s > 10.0\ \text{m/sec}$	60 HRC

### Surface roughness

$Ra^*$	0.2 to 0.8 $\mu\text{m}$
$Rz$	1.0 to 4.0 $\mu\text{m}$
$Rmax$	$\leq 6.3\ \mu\text{m}$

\* $Ra = 0.1\ \mu\text{m}$  for demanding applications

### Rotating hub tolerance

Rotating hub diameter $\text{Ø}D1$ (mm)	Tolerance H11 (mm)
$3.0 < \text{Ø}D1 \leq 6.0$	0 / +0.075
$6.0 < \text{Ø}D1 \leq 10.0$	0 / +0.090
$10.0 < \text{Ø}D1 \leq 18.0$	0 / +0.110
$18.0 < \text{Ø}D1 \leq 30.0$	0 / +0.130
$30.0 < \text{Ø}D1 \leq 50.0$	0 / +0.160
$50.0 < \text{Ø}D1 \leq 80.0$	0 / +0.190
$80.0 < \text{Ø}D1 \leq 120.0$	0 / +0.220
$120.0 < \text{Ø}D1 \leq 180.0$	0 / +0.250
$180.0 < \text{Ø}D1 \leq 250.0$	0 / +0.290
$250.0 < \text{Ø}D1 \leq 315.0$	0 / +0.320
$315.0 < \text{Ø}D1 \leq 400.0$	0 / +0.360
$400.0 < \text{Ø}D1 \leq 500.0$	0 / +0.400

### Chamfer and radius

Rotating hub diameter $\text{Ø}D1$ (mm)	Chamfer diameter $\text{Ø}D3$ (mm)	Radius R (mm)
$\text{Ø}D1 \leq 10.0$	$\text{Ø}D1 + 1.50$	2.00
$10.0 < \text{Ø}D1 \leq 20.0$	$\text{Ø}D1 + 2.00$	2.00
$20.0 < \text{Ø}D1 \leq 30.0$	$\text{Ø}D1 + 2.50$	3.00
$30.0 < \text{Ø}D1 \leq 40.0$	$\text{Ø}D1 + 3.00$	3.00
$40.0 < \text{Ø}D1 \leq 50.0$	$\text{Ø}D1 + 3.50$	4.00
$50.0 < \text{Ø}D1 \leq 70.0$	$\text{Ø}D1 + 4.00$	4.00
$70.0 < \text{Ø}D1 \leq 95.0$	$\text{Ø}D1 + 4.50$	5.00
$95.0 < \text{Ø}D1 \leq 130.0$	$\text{Ø}D1 + 5.50$	6.00
$130.0 < \text{Ø}D1 \leq 240.0$	$\text{Ø}D1 + 7.00$	8.00
$240.0 < \text{Ø}D1 \leq 500.0$	$\text{Ø}D1 + 11.00$	12.00

### Rotating hub run out and eccentricity

