

STANDARD SHAFT SEALS

DBCW

DESCRIPTION

The DBCW profile is a shaft seal composed of a single external metal cage with rubber grooves covering half of the outside of the cage and a double primary sealing lip with integrated springs to separate the fluids.

ADVANTAGES

- Good radial rigidity, particularly for large diameters
- Good stability when assembled, preventing the bounce-back effect
- Good static sealing
- Good thermal expansion compensation
- Good heat transfer
- Easy to assemble with very limited bounce-back effect
- Sealing for low and high viscosity fluids
- Modern sealing lips with low radial forces
- Fluid separation system

APPLICATIONS

- All types of rotative applications
- Machine tools Gear boxes
- Agriculture Motors
- Construction Pumps
- Transmission

MATERIALS

- Rubber**
- ACM 70 - 75 Shore A
- EPDM 70 - 75 Shore A
- FKM 70 - 75 Shore A
- HNBR 70 - 75 Shore A
- NBR 70 - 75 Shore A
- Metal cage**
- Steel - AISI 1010
- Stainless steel - AISI 304
- Stainless steel - AISI 316
- Spring**
- Steel - AISI 1070 - 1090
- Stainless steel - AISI 316

SEAL DESIGN

Tolerance for the outside diameter of the seal (ØD)

Bore diameter ØD1 (mm)	Apparent metal cage	Rubber coating	Coating with grooves
ØD1 ≤ 50.0	+0.10 / +0.20	+0.15 / +0.30	+0.20 / +0.40
50.0 < ØD1 ≤ 80.0	+0.13 / +0.23	+0.20 / +0.35	+0.25 / +0.45
80.0 < ØD1 ≤ 120.0	+0.15 / +0.25	+0.20 / +0.35	+0.25 / +0.45
120.0 < ØD1 ≤ 180.0	+0.18 / +0.28	+0.25 / +0.45	+0.30 / +0.55
180.0 < ØD1 ≤ 300.0	+0.20 / +0.30	+0.25 / +0.45	+0.30 / +0.55
300.0 < ØD1 ≤ 500.0	+0.23 / +0.35	+0.30 / +0.55	+0.35 / +0.65
500.0 < ØD1 ≤ 630.0	+0.23 / +0.35	+0.35 / +0.65	+0.40 / +0.75

Roundness tolerance

Bore diameter ØD1 (mm)	Apparent metal cage	Rubber coating
ØD1 ≤ 50.0	0.18	0.25
50.0 < ØD1 ≤ 80.0	0.25	0.35
80.0 < ØD1 ≤ 120.0	0.30	0.50
120.0 < ØD1 ≤ 180.0	0.40	0.65
180.0 < ØD1 ≤ 300.0	0.25% of the outside diameter	0.80
300.0 < ØD1 ≤ 500.0	0.25% of the outside diameter	1.00
500.0 < ØD1 ≤ 630.0	-	-

Tolerance for the inside diameter of the seal (Ød)

Free and without constraint, the inside diameter of the sealing lip is always smaller than the diameter of the shaft. The pre-tightening or interference denotes the difference between these two values. Depending on the shaft diameter, the diameter of the sealing lip is generally considered to be less, between 0.8 and 3.5 mm.

Pumping leads

Clockwise	Anti-clockwise	Bi-directional
R	L	H0

Other types of pumping leads can be created according to your specifications. Please contact our experts.

TECHNICAL DATA

Speed

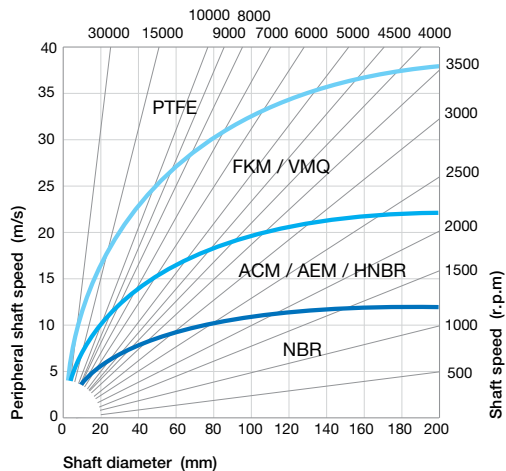

The shaft seals with an additional protective lip are limited to a speed of 8 m/sec.

Linear speed calculation:

$$s \text{ (m/s)} = \frac{[\text{shaft } \varnothing \text{ (mm)} \times \text{speed (rpm)} \times \pi]}{60,000}$$

Pressure

The standard shaft seals are generally used in unpressurised environments, or for pressures between 0.02 and 0.05 MPa maximum.

Higher pressures are acceptable, following testing, for standard NBR or FKM shaft seals used on a shaft diameter less than 30 mm.

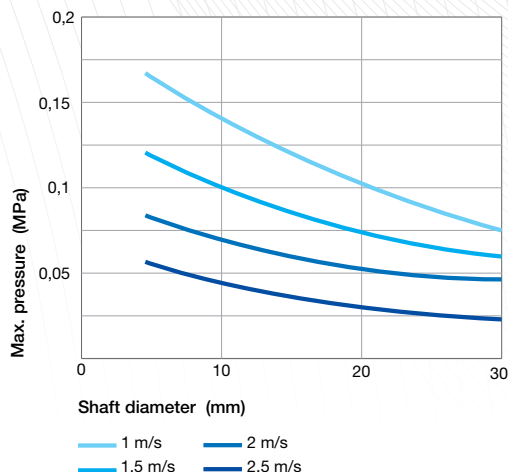

Temperature / Media

Media		Maximum temperature depending on the materials						
		ACM	AEM	EPDM	FKM	HNBR	NBR	VMQ
Mineral oils	Oils for motors	+130°C	+130°C	-	+170°C	+130°C	+100°C	+150°C
	Oils for gearboxes	+120°C	+130°C	-	+150°C	+110°C	+80°C	+130°C
	Oils for hypoid gears	+120°C	+130°C	-	+150°C	+110°C	+80°C	-
	ATF oils	+120°C	+130°C	-	+170°C	+130°C	+100°C	-
	Hydraulic oils	+120°C	+130°C	-	+150°C	+130°C	+90°C	-
	Greases	-	+130°C	-	-	+100°C	+90°C	-
Fire-resistant fluids	HFA group - Emulsion with more than 80% water	-	-	-	-	+70°C	+70°C	+60°C
	HFB group - Opposite solution (water in oil)	-	-	-	-	+70°C	+70°C	+60°C
	HFC group - Polymer aqueous solution	-	-	+60°C	-	+70°C	+70°C	-
	HFD group - Water-free synthetic fluids	-	-	-	+150°C	-	-	-
Other fluids	EL + L heating oil	-	-	-	-	+100°C	+90°C	-
	Air	+150°C	+150°C	+150°C	+200°C	+130°C	+100°C	+200°C
	Water	-	-	+150°C	+100°C	+100°C	+90°C	-
	Water for washing	-	-	+130°C	+100°C	+100°C	+90°C	-
Temperature range	Min.	-25°C	-40°C	-45°C	-20°C	-30°C	-30°C	-60°C
	Max.	+150°C	+150°C	+150°C	+200°C	+150°C	+100°C	+200°C

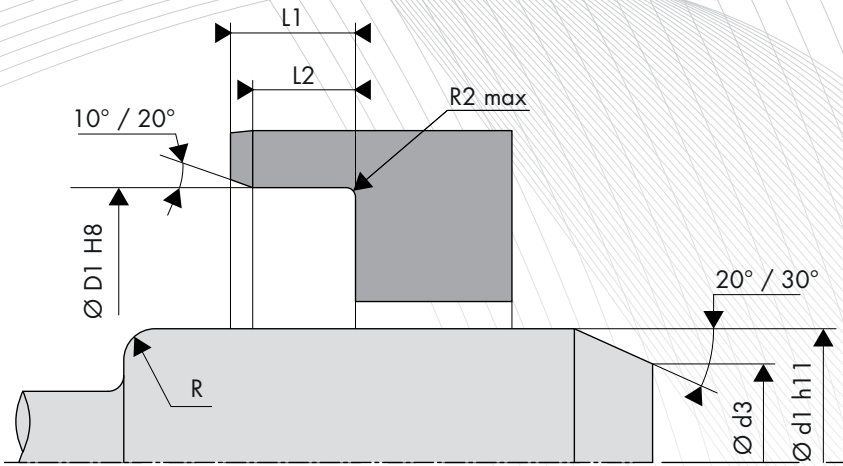

SHAFT DESIGN

Shaft hardness

Rotation speed	Hardness in HRC
$s \leq 4.0$ m/sec	45 HRC
$4.0 < s \leq 10.0$ m/s	55 HRC
$s > 10.0$ m/sec	60 HRC

Surface roughness

Ra *	0.2 to 0.8 μm
Rz	1.0 to 4.0 μm
Rmax	≤ 6.3 μm

*Ra = 0.1 μm for demanding applications

Shaft tolerance

Shaft diameter $\varnothing d1$ (mm)	Tolerance h11 (mm)
$\varnothing d1 \leq 3.0$	-0.060 / 0
$3.0 < \varnothing d1 \leq 6.0$	-0.075 / 0
$6.0 < \varnothing d1 \leq 10.0$	-0.090 / 0
$10.0 < \varnothing d1 \leq 18.0$	-0.110 / 0
$18.0 < \varnothing d1 \leq 30.0$	-0.130 / 0
$30.0 < \varnothing d1 \leq 50.0$	-0.160 / 0
$50.0 < \varnothing d1 \leq 80.0$	-0.190 / 0
$80.0 < \varnothing d1 \leq 120.0$	-0.220 / 0
$120.0 < \varnothing d1 \leq 180.0$	-0.250 / 0
$180.0 < \varnothing d1 \leq 250.0$	-0.290 / 0
$250.0 < \varnothing d1 \leq 315.0$	-0.320 / 0
$315.0 < \varnothing d1 \leq 400.0$	-0.360 / 0
$400.0 < \varnothing d1 \leq 500.0$	-0.400 / 0

Chamfer and radius

Shaft diameter $\varnothing d1$ (mm)	Chamfer diameter $\varnothing d3$ (mm)	Radius R (mm)
$\varnothing d1 \leq 10.0$	$\varnothing d1 - 1.50$	2.00
$10.0 < \varnothing d1 \leq 20.0$	$\varnothing d1 - 2.00$	2.00
$20.0 < \varnothing d1 \leq 30.0$	$\varnothing d1 - 2.50$	3.00
$30.0 < \varnothing d1 \leq 40.0$	$\varnothing d1 - 3.00$	3.00
$40.0 < \varnothing d1 \leq 50.0$	$\varnothing d1 - 3.50$	4.00
$50.0 < \varnothing d1 \leq 70.0$	$\varnothing d1 - 4.00$	4.00
$70.0 < \varnothing d1 \leq 95.0$	$\varnothing d1 - 4.50$	5.00
$95.0 < \varnothing d1 \leq 130.0$	$\varnothing d1 - 5.50$	6.00
$130.0 < \varnothing d1 \leq 240.0$	$\varnothing d1 - 7.00$	8.00
$240.0 < \varnothing d1 \leq 500.0$	$\varnothing d1 - 11.00$	12.00

Shaft run out

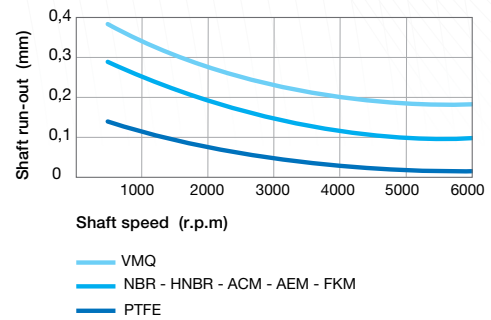

Eccentricity

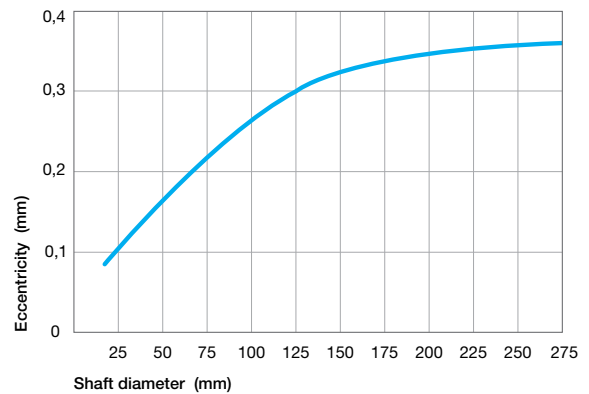

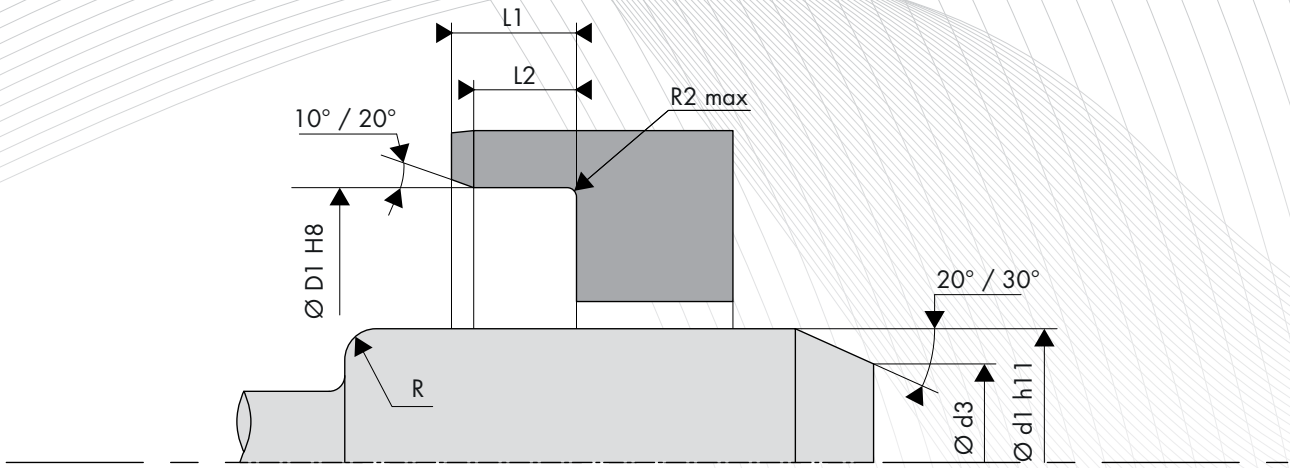

HOUSING DESIGN

Surface roughness

Ra	0.8 to 3.2 µm
Rz	6.3 to 16.0 µm
Rmax	≤16.0 µm

Housing tolerance

Bore diameter ØD1 (mm)	Tolerance H8 (mm)
3.0 < ØD1 ≤ 6.0	0 / +0.018
6.0 < ØD1 ≤ 10.0	0 / +0.022
10.0 < ØD1 ≤ 18.0	0 / +0.027
18.0 < ØD1 ≤ 30.0	0 / +0.033
30.0 < ØD1 ≤ 50.0	0 / +0.039
50.0 < ØD1 ≤ 80.0	0 / +0.046
80.0 < ØD1 ≤ 120.0	0 / +0.054
120.0 < ØD1 ≤ 180.0	0 / +0.063
180.0 < ØD1 ≤ 250.0	0 / +0.072
250.0 < ØD1 ≤ 315.0	0 / +0.081
315.0 < ØD1 ≤ 400.0	0 / +0.089
400.0 < ØD1 ≤ 500.0	0 / +0.097
500.0 < ØD1 ≤ 630.0	0 / +0.110

Housing radius and width

Height H1 (mm)	Width		Radius R2 max (mm)
	L2min (H1 x 0.85)	L1min (H1 x +0.3)	
7.00	5.95	7.30	0.50
8.00	6.80	8.30	
10.00	8.50	10.30	
12.00	10.30	12.30	0.70
15.00	12.75	15.30	
20.00	17.00	20.30	