

TRIPLE-LIP SHAFT SEALS

OKBL3

DESCRIPTION

The OKBL3 profile is an inverted shaft seal composed of an internal metal cage and a triple sealing lip.

ADVANTAGES

Good radial rigidity, particularly for large diameters

Good stability when assembled, preventing the bounce-back effect

Grease retention

External contaminant retention (mud and water), environments with heavy-duty applications

Suitable for rotating hubs with a fixed shaft

APPLICATIONS

All types of rotative applications

Rotating hubs

Fixed shafts

MATERIALS

Rubber

FKM 70 - 75 Shore A

HNBR 70 - 75 Shore A

NBR 70 - 75 Shore A

Metal cage

Steel - AISI 1010

Stainless steel - AISI 304

Stainless steel - AISI 316

SEAL DESIGN

Tolerance for the inside diameter of the seal ($\varnothing d$)

Shaft diameter $\varnothing d1$ (mm)	Apparent metal cage	Rubber coating	Coating with grooves
$\varnothing d1 \leq 50.0$	-0.20 / -0.10	-0.30 / -0.15	-0.40 / -0.20
$50.0 < \varnothing d1 \leq 80.0$	-0.23 / -0.13	-0.35 / -0.20	-0.45 / -0.25
$80.0 < \varnothing d1 \leq 120.0$	-0.25 / -0.15	-0.35 / -0.20	-0.45 / -0.25
$120.0 < \varnothing d1 \leq 180.0$	-0.28 / -0.18	-0.45 / -0.25	-0.55 / -0.30
$180.0 < \varnothing d1 \leq 300.0$	-0.30 / -0.20	-0.45 / -0.25	-0.55 / -0.30
$300.0 < \varnothing d1 \leq 500.0$	-0.35 / -0.23	-0.55 / -0.30	-0.65 / -0.35

Roundness tolerance

Shaft diameter $\varnothing d1$ (mm)	Apparent metal cage	Rubber coating
$\varnothing d1 \leq 50.0$	0.18	0.25
$50.0 < \varnothing d1 \leq 80.0$	0.25	0.35
$80.0 < \varnothing d1 \leq 120.0$	0.30	0.50
$120.0 < \varnothing d1 \leq 180.0$	0.40	0.65
$180.0 < \varnothing d1 \leq 300.0$	0.25% of the inside diameter	0.80
$300.0 < \varnothing d1 \leq 500.0$	0.25% of the inside diameter	1.00

Tolerance for the outside diameter of the seal ($\varnothing D$)

Free and without constraint, the outside diameter of the sealing lips is always bigger than the diameter of the rotating hub. The pre-tightening or interference denotes the difference between these two values. Depending on the diameter of the rotating hub, the diameter of the sealed lips is generally considered to be greater, between 0.8 and 3.5 mm.

TECHNICAL DATA

Speed

The triple-lip shaft seals can support a maximum speed of 2.5 m/s.

Linear speed calculation:

$$s \text{ (m/s)} = \frac{[\text{rotating hub } \varnothing \text{ (mm)} \times \text{speed (rpm)} \times \pi]}{60,000}$$

Pressure

The triple-lip shaft seals are generally used in unpressurised environments, or for pressures between 0.02 and 0.05 MPa maximum.

Temperature / Media

Media		Maximum temperature depending on the materials						
		ACM	AEM	EPDM	FKM	HNBR	NBR	VMQ
Mineral oils	Oils for motors	+130°C	+130°C	–	+170°C	+130°C	+100°C	+150°C
	Oils for gearboxes	+120°C	+130°C	–	+150°C	+110°C	+80°C	+130°C
	Oils for hypoid gears	+120°C	+130°C	–	+150°C	+110°C	+80°C	–
	ATF oils	+120°C	+130°C	–	+170°C	+130°C	+100°C	–
	Hydraulic oils	+120°C	+130°C	–	+150°C	+130°C	+90°C	–
	Greases	–	+130°C	–	–	+100°C	+90°C	–
Fire-resistant fluids	HFA group - Emulsion with more than 80% water	–	–	–	–	+70°C	+70°C	+60°C
	HFB group - Opposite solution (water in oil)	–	–	–	–	+70°C	+70°C	+60°C
	HFC group - Polymer aqueous solution	–	–	+60°C	–	+70°C	+70°C	–
	HFD group - Water-free synthetic fluids	–	–	–	+150°C	–	–	–
Other fluids	EL + L heating oil	–	–	–	–	+100°C	+90°C	–
	Air	+150°C	+150°C	+150°C	+200°C	+130°C	+100°C	+200°C
	Water	–	–	+150°C	+100°C	+100°C	+90°C	–
	Water for washing	–	–	+130°C	+100°C	+100°C	+90°C	–
Temperature range	Min.	-25°C	-40°C	-45°C	-20°C	-30°C	-30°C	-60°C
	Max.	+150°C	+150°C	+150°C	+200°C	+150°C	+100°C	+200°C

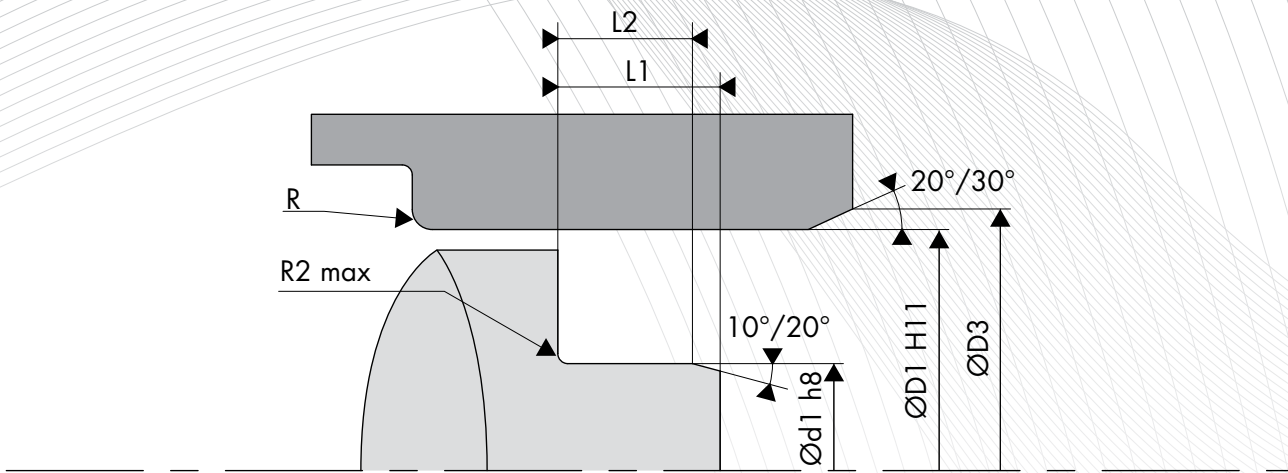

FIXED SHAFT DESIGN

Surface roughness

Ra	0.8 to 3.2 μm
Rz	6.3 to 16.0 μm
Rmax	≤ 16.0 μm

Fixed shaft tolerance

Shaft diameter Ød1 (mm)	Tolerance h8 (mm)
$3.0 < \text{Ød1} \leq 6.0$	-0.018 / 0
$6.0 < \text{Ød1} \leq 10.0$	-0.022 / 0
$10.0 < \text{Ød1} \leq 18.0$	-0.027 / 0
$18.0 < \text{Ød1} \leq 30.0$	-0.033 / 0
$30.0 < \text{Ød1} \leq 50.0$	-0.039 / 0
$50.0 < \text{Ød1} \leq 80.0$	-0.046 / 0
$80.0 < \text{Ød1} \leq 120.0$	-0.054 / 0
$120.0 < \text{Ød1} \leq 180.0$	-0.063 / 0
$180.0 < \text{Ød1} \leq 250.0$	-0.072 / 0
$250.0 < \text{Ød1} \leq 315.0$	-0.081 / 0
$315.0 < \text{Ød1} \leq 400.0$	-0.089 / 0
$400.0 < \text{Ød1} \leq 500.0$	-0.097 / 0

Fixed shaft radius and width

Height H1 (mm)	Width		Radius R2 max (mm)
	L2min (H1 x 0.85)	L1 min (H1 x +0.3)	
7.00	5.95	7.30	0.50
8.00	6.80	8.30	
10.00	8.50	10.30	
12.00	10.30	12.30	
15.00	12.75	15.30	0.70
20.00	17.00	20.30	

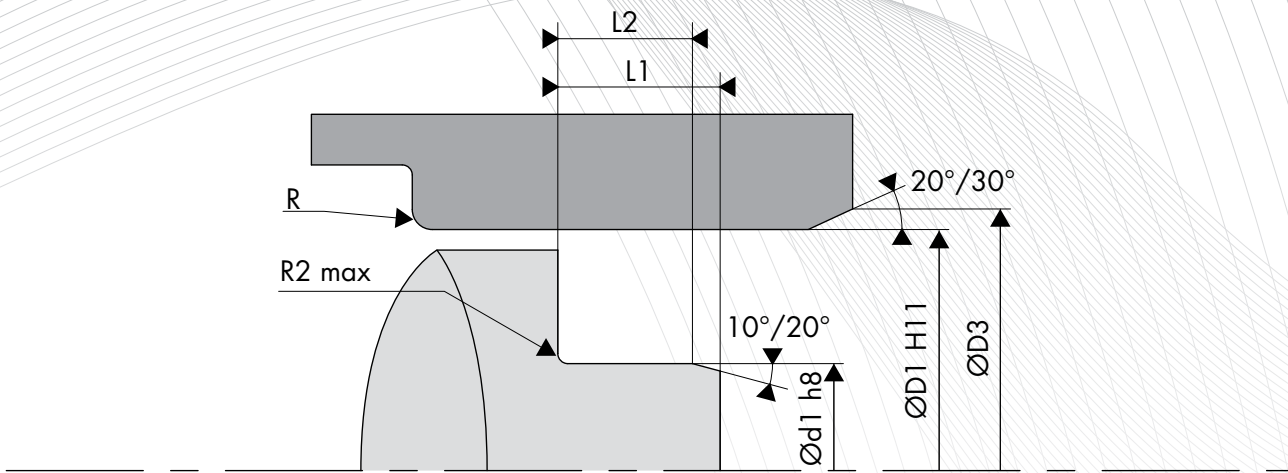

○ ROTATING HUB DESIGN

Rotating hub hardness

Rotation speed	Hardness in HRC
$s \leq 4.0$ m/sec	45 HRC
$4.0 < s \leq 10.0$ m/s	55 HRC
$s > 10.0$ m/sec	60 HRC

Surface roughness

Ra *	0.2 to 0.8 μm
Rz	1.0 to 4.0 μm
Rmax	≤ 6.3 μm

*Ra = 0.1 μm for demanding applications

Chamfer and radius

Rotating hub diameter ØD1 (mm)	Chamfer diameter ØD3 (mm)	Radius R (mm)
$\text{ØD1} \leq 10.0$	$\text{ØD1} + 1.50$	2.00
$10.0 < \text{ØD1} \leq 20.0$	$\text{ØD1} + 2.00$	2.00
$20.0 < \text{ØD1} \leq 30.0$	$\text{ØD1} + 2.50$	3.00
$30.0 < \text{ØD1} \leq 40.0$	$\text{ØD1} + 3.00$	3.00
$40.0 < \text{ØD1} \leq 50.0$	$\text{ØD1} + 3.50$	4.00
$50.0 < \text{ØD1} \leq 70.0$	$\text{ØD1} + 4.00$	4.00
$70.0 < \text{ØD1} \leq 95.0$	$\text{ØD1} + 4.50$	5.00
$95.0 < \text{ØD1} \leq 130.0$	$\text{ØD1} + 5.50$	6.00
$130.0 < \text{ØD1} \leq 240.0$	$\text{ØD1} + 7.00$	8.00
$240.0 < \text{ØD1} \leq 500.0$	$\text{ØD1} + 11.00$	12.00

Rotating hub tolerance

Rotating hub diameter ØD1 (mm)	Tolerance H11 (mm)
$3.0 < \text{ØD1} \leq 6.0$	0 / +0.075
$6.0 < \text{ØD1} \leq 10.0$	0 / +0.090
$10.0 < \text{ØD1} \leq 18.0$	0 / +0.110
$18.0 < \text{ØD1} \leq 30.0$	0 / +0.130
$30.0 < \text{ØD1} \leq 50.0$	0 / +0.160
$50.0 < \text{ØD1} \leq 80.0$	0 / +0.190
$80.0 < \text{ØD1} \leq 120.0$	0 / +0.220
$120.0 < \text{ØD1} \leq 180.0$	0 / +0.250
$180.0 < \text{ØD1} \leq 250.0$	0 / +0.290
$250.0 < \text{ØD1} \leq 315.0$	0 / +0.320
$315.0 < \text{ØD1} \leq 400.0$	0 / +0.360
$400.0 < \text{ØD1} \leq 500.0$	0 / +0.400

Overall eccentricity

Rotating hub diameter ØD1 (mm)	Overall eccentricity (mm)
$\text{ØD1} \leq 40.00$	0.15
$40.00 < \text{ØD1} \leq 80.00$	0.20
$80.00 < \text{ØD1} \leq 120.00$	0.30